

CVS3-RA SERIES

MVS Series

CVS Series

CVS Series APPLICATION

CVSE1-RA

CVS1-RA

CVS2-RA

CVS3-RA

CVS4-RA

OPTIONS



Edge sensor for various application

- All in one color vision sensor
- Easy setup and High performance
- Useful Zoom-in function

Wide range line-up

CVS3-N20-RA Standard type
CVS3-N21-RA Narrow view type

New inspection mode: Contour mode, Differential mode

New inspection mode, Contour mode and Differential mode have been added up on conventional CVS3-RA compatible mode. It has improved search function and improved color/contrast correct function.

Masking function

You can mask the area that doesn't have to be checked so that you can get better sensitivity of inspection.



Zoom function

CVS3-RA has Zoom function so you can zoom in up to twice size.

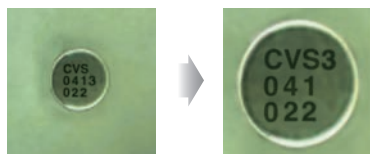

	Compatible mode	Contour mode	Differential mode
Mode			
Application	<p>Metal parts</p>	<p>Metal parts Contour mode+Monochrome mode</p> <p>For flaw with slight color difference Contour mode+Color inspection</p> <p>For slight color difference and shape Contour mode+inspection of entire area</p>	<p>Checking picture Differential mode</p> <p>For low contrast object Differential mode+Color inspection</p>

Downloading setup parameters to PC

You can download setup data and reference image data into PC. You can copy the reference image data and the setup data to other CVS3-RA. Please use I/F cable CVS-C2C.

Up to 15 Bank

15 Banks are available in small all in one package.

Other FOV type is available

In case you need other FOV type like CVS1-RA or CVS2-RA, please contact our distributor.

Features

7 binarize level

When it compares binarized image between registered image and captured image, it chooses best binarize level to get best image automatically. This is effective when the lighting is not stable.

Existence of graved mark on metal or glass



Rotate correction

Correction of rotation is available up to +/- 6.2 degree.

Inspection of chocolate shape



Find out best angle rotating the captured image step by step



Detecting Color edge

Detect edge between different colors and get clear image to inspect.

Inspection of colored label direction



You can detect even red color on green background easily that monochrome camera can't.



Easy Teaching

You can externally teach CVS3-R just by inputting single Teaching signal. Then, CVS3-RA updates its image for reference automatically.

Verifying shelf life that changes everyday



Display

Compatible mode



- 1 Captured image
Image captured by the camera
- 2 Parameters
Shows parameters
- 3 Lack/Stain pixels
Shows lack of edge and stain on the background
- 4 Stablensness of threshold level
↑ : Increase THRESHLD
↓ : Decrease THRESHLD
- 5 Display mode
Shows current display mode
- 6 Judge result
Shows judge result
- 7 Bank No./Response time
Shows Bank No. in normal mode. Shows response time while setup mode

Contour mode

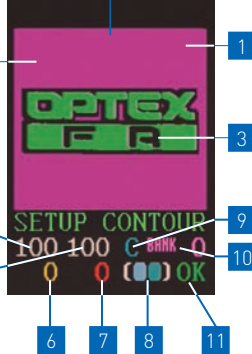

- 1 Area to detect stain
It shows pixel in red when it matches to the contour and Stain pixel No. will be increased
- 2 Area to detect lack of contour
It shows pixel in yellow when it's detected as lack of contour and Lack pixel No. will be increased
- 3 Area to neglect
It doesn't affect anything even if there is contour in this area
- 4 Threshold of lack of contour
- 5 Threshold of stain
- 6 Lack pixel No.
- 7 Stain pixel No.
- 8 Registered color (bright / dark)
- 9 Display mode
- 10 Bank No.
- 11 Judge result

Differential mode

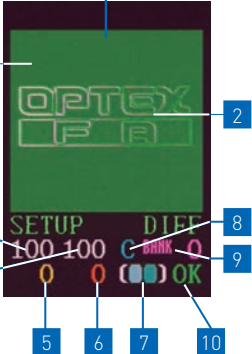

- 1 Area without contour
It shows pixel in yellow or red when it detect contour and differential rate will be increased
- 2 Area with contour should exist
It shows pixel in yellow or red when it doesn't detect contour and differential rate will be increased
- 3 Threshold of differential rate
- 4 Threshold of color area rate
- 5 Differential rate
- 6 Color area rate
- 7 Registered color (bright / dark)
- 8 Display mode
- 9 Bank No.
- 10 Judge result

Switches



- UP**
Move cursor up and increase parameter value
- DOWN**
Move cursor down and decrease parameter value
- VIEW**
Change the display mode
F: Dark Compensated image
2: Shows only chosen color area
D: Shows original image
- EXIT**
Use this button when you quit changing parameter and going back to previous menu.
- SET**
Change and set the parameters.

Specifications

Model	CVS3-N20-RA CVS3-P20-RA	CVS3-N21-RA CVS3-P21-RA
Detection angle	20°	
Working distance	90 to 150mm	31 to 39mm
Field of view	40 x 50mm to 65 x 75mm	17 x 20mm (±10%)
Light source	White LED 12 pcs built-in	
Image sensor	330,000 Pixel CMOS color image sensor	
Supply Voltage	12 to 24V DC±10%	
Power consumption	Max. 140mA/24V DC	
Resolution	16 x 16 to 208 x 236	
LED light duration	Approx.50,000 hours(In normal temperature and humidity. Brightness level down by 1/3 of the initial level)	
Response time	Contour mode : 148ms (Factory Settings)	
Output	NPN or PNP open collector output x 2 max. 100mA Residual voltage 1.0V or less	
Input	Totally 4: Bank select 0-3, Bank select 2 (switchable to Bank select 3 or NG output)	
Operating temperature	0 to 40°C (No condensation)	
Operating humidity	35 to 85%RH	
Storage temperature/humidity	-20 to 70°C, 35 to 95%RH (No condensation)	
Vibration/shock resistance	10 to 55Hz Amplitude 1.5mm / 50G (500m/s ²)	
Material	Case:ABS / Display and Lens : Acryl or Polycarbonate	
Protection structure	IP67	
Weight	Approx.200g (including cable)	

Connection diagram

(NPN)

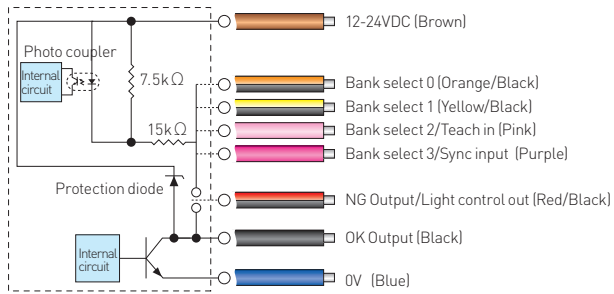

(PNP)

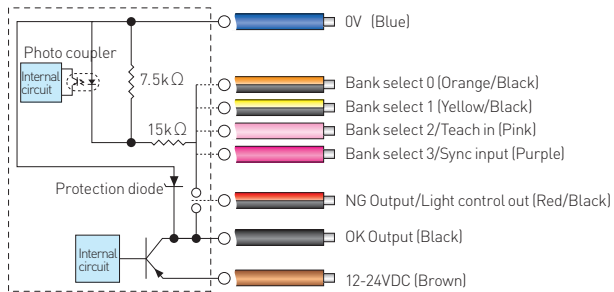

Bank table

Set up	BANK	0-14		15		16	
	SYNCHRON	4	0-3	4	0-3	4	0-3
External Input	Bank select 0	NA		Active			
	Bank select 1	NA		Active			
	Bank select 2	External Teach-in				Active	
	Bank select 3	NA	Synch.In	Active	Synch.In	Active	Synch.In

Bank No.	Bank select input			
	3(Purple)	2(Pink)	1(Yellow/Black)	0(Orange/Black)
0	OFF	OFF	OFF	OFF
1	OFF	OFF	OFF	ON
2	OFF	OFF	ON	OFF
3	OFF	OFF	ON	ON
4	OFF	ON	OFF	OFF
5	OFF	ON	OFF	ON
6	OFF	ON	ON	OFF
7	OFF	ON	ON	ON
8	ON	OFF	OFF	OFF
9	ON	OFF	OFF	ON
10	ON	OFF	ON	OFF
11	ON	OFF	ON	ON
12	ON	ON	OFF	OFF
13	ON	ON	OFF	ON
14	ON	ON	ON	OFF
0	ON	ON	ON	ON

OFF	NPN: OPEN or connect with the brown line. PNP: OPEN or connect with the blue line.
ON	NPN: connect with the blue line. PNP: connect with the brown line.

Field of View

CVS3-N20-R Standard type

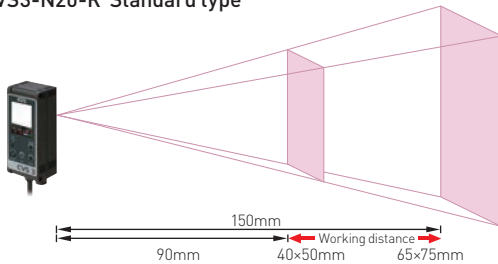

CVS3-N21-R Narrow view type

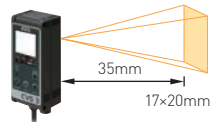

7. Checking existence of label on package



CVSE1-RA

Set the major color on the label and check its area in the field of view

8. Checking existence of needle cap



CVS1-RA

Existence of needle cap can be detected easily by color area inspection even in a big FOV

9. Checking shelf life on the milk package



CVS4-R

Check the date of shelf life on milk package. It has calendar function so checking overnight is available

10. Checking expiration date on the package



CVS4-R

Check the expiration date on the package. It can just check number of character as well

11. Checking existence of description of pills



CVSE1-RA

Set the color area of description of pills in the field of view

12. Checking overlapping of the label



CVS3-RA

Check the overlapping label by its edge detection function

13. Checking marking on electric components



CVSE1-RA

Set the color of the marking and check its area in the field of view. Narrow angle view version can zoom up small area.

14. Checking ON/OFF of LED on PWB



CVS2-RA

Check the color and position of LED by its color pattern matching function

15. Checking order of the color of wires



CVS2-RA

Check the color and position of wires by its color pattern matching function

16. Checking existence of bad marking on parts



CVS2-RA

Check color of the parts and color of bad marking on the parts to detect existence of bad parts

17. Checking existence of wafer

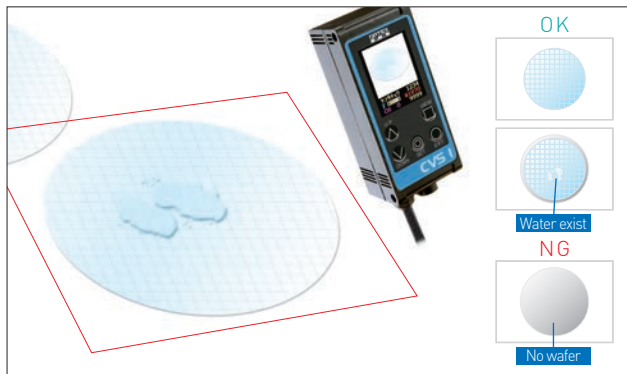

CVS1-RA

Set the color of the wafer as its reference and detect existence of the wafer even there are some water on it

18. Checking direction of the parts



CVS3-RA

Check the edge of the marking on the IC package and detect direction of it

19. Checking position of welded part



CVS2-RA

Set the color of the pipe and welded part and detect welded part stably by its pattern matching function

20. Checking shape of assembled parts



CVS3-RA

Check the shape of the assembled parts by edge detecting function utilizing back lighting

21. Checking direction of the parts on conveyor



CVS2-RA

Check the color and position of the surface pattern by its color pattern matching function

22. Checking size of the nut



CVS3-RA

Check size of the nut by edge detecting function

23. Checking characters on metal parts



CVS4-R

Check the characters engraved on the metal parts by its OCR function

24. Checking existence of lot number on the spark plugs



CVS1-RA

Check the color area of the printed characters on the spark plugs

Accessories for CVS series

Remote monitor (with 3m cable)



CVS-M1-R
For CVS series

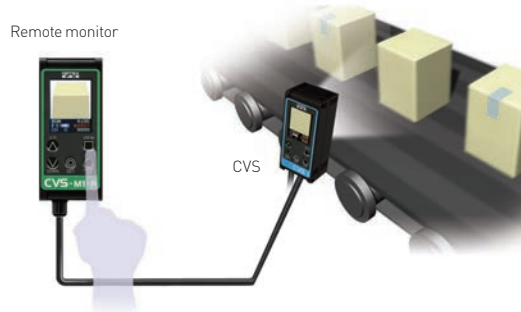

You can control from Remote monitor that has LCD and buttons to control remotely. The buttons work same as CVS series itself.

PC I/F cable (2m)

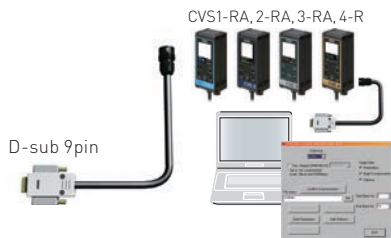

CVS-C2C
For CVS1-RA, 2-RA, 3-RA, 4-R

You can download the I/F software from our homepage. You can setup CVS1-RA, CVS2-RA, CVS3-RA and CVS4-R through each software and can get registered image. You can also modify mask area easily on the PC display.

Required PC spec.
- Microsoft Windows 7
- RS232 I/F
Software is downloadable from <http://www.optex-fa.com>

Video cable (3m)



CVS-CN
For CVS series

You can see the display image connecting standard TV monitor (NTSC).

PC I/F cable + I/F cable for Video Out (2m)



CVS-C2Y
For CVS1-RA,2-RA,3-RA,4-R

You can connect PC and CVS-M1-R. You can see the screen image on the CVS-M1-R.
* You can't control through CVS-M1-R.

Extension cable for Remote monitor (3m)



CVS-C3S
For CVS-M1-R

You can connect Remote monitor through this cable up to 15m (4 CVS-C3S = 12m + 3m cable of Remote monitor)

PC I/F cable + Video cable (2m)



CVS-C2P(2m)
For CVS1-RA,2-RA,3-RA,4-R

You can connect PC and get video signal at a time.

External LED lighting

When you need brighter lighting and/or lighting from other direction to get better image, you can utilize external LED lighting. Please refer Page 54 for other lighting and power supply.

High brightness Bar LED lighting with bracket



OPDB-50x15WS

OPB-5015W2-B
50x15mm
OPB-10015W2-B
100x15mm

Power supply LED controller



OPPD-15

Bracket for Lighting



CVS-OPDB-2000
CVS-OPDB-3040
CVS-OPDB-6080

2 OPDB-50x15WS and CVS-OPDB-2000



CVS-OP1000L
This is for mounting CVS series and external LED lighting.

Dimensions

CVS Series

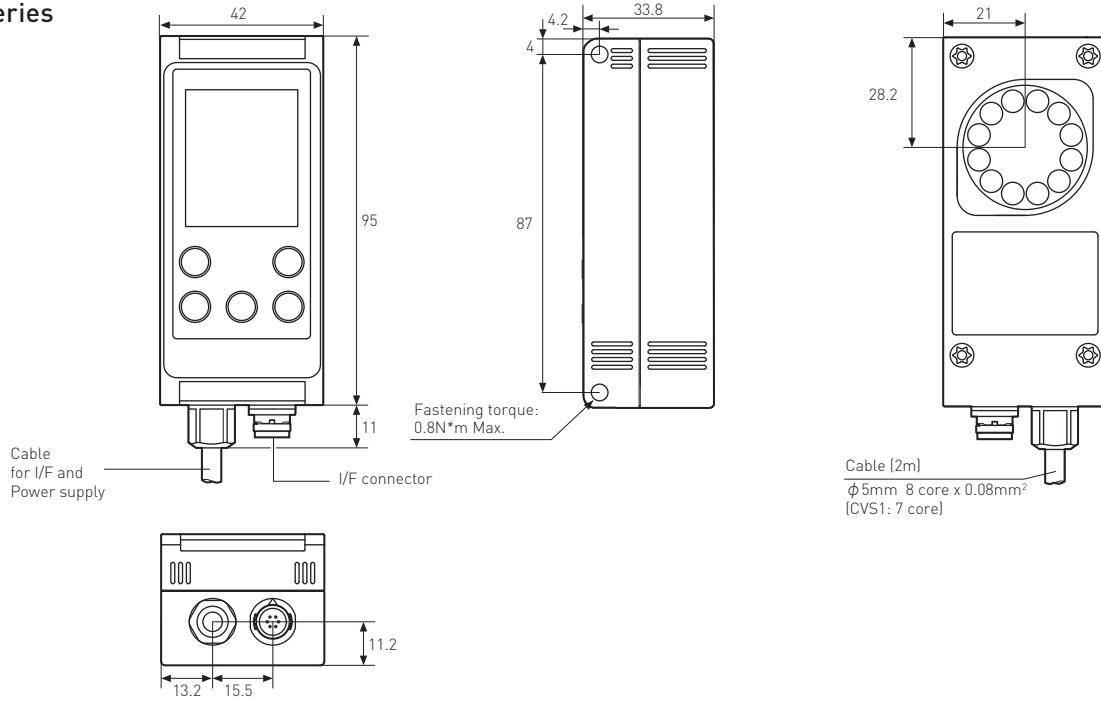

Remote monitor CVS-M1-R

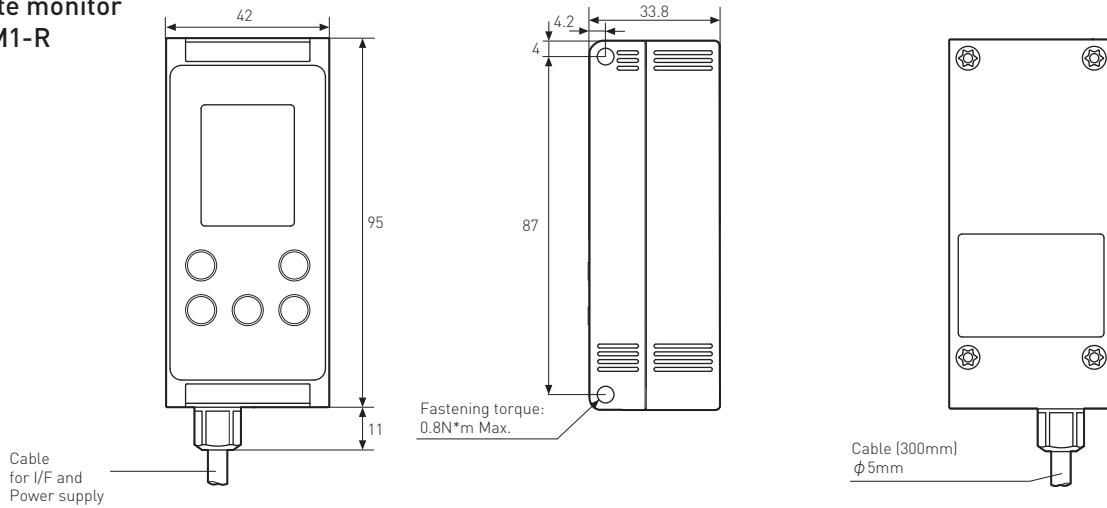

(unit: mm)

Tips for mounting CVS series

- Please determine Working distance and Field of View so that you choose correct model number of CVS series.
- Please use M4 * 50mm screws to mount CVS series
- Please take care about distance between CVS and target object to get stable size of Field of View.
- Please mount CVS at 15 to 45 degree to prevent specular reflection from the object especially from glossy object.
- When the object moves fast, you have to set shutter speed shorter. Then, you will need brighter lighting to get better image. Please try external lighting in this case.

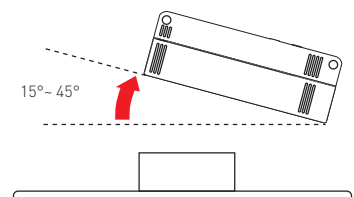

**Bracket for Lighting
CVS-OPDB-2000**

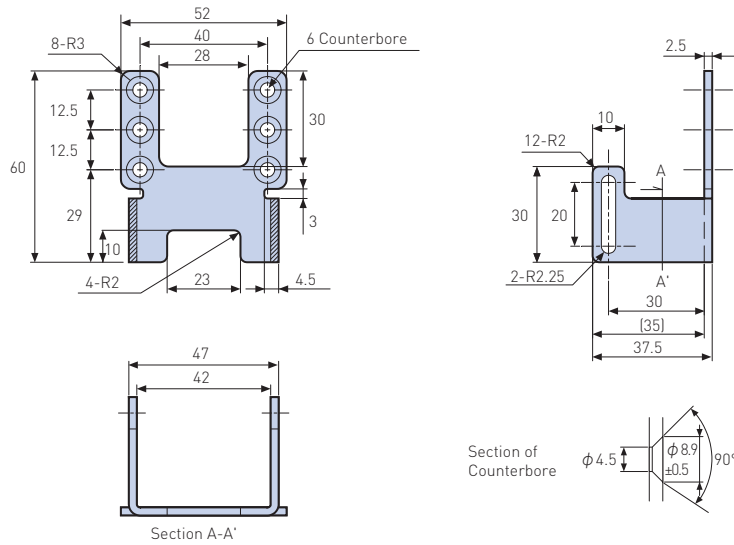

CVS-OPDB-3040

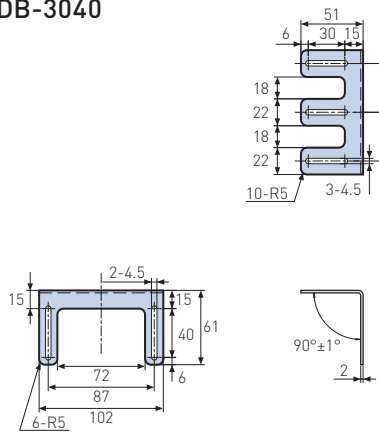

CVS-OPDB-6080

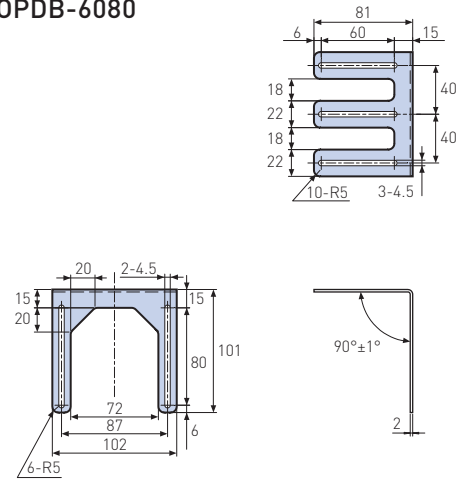

CVS-OP-1000L

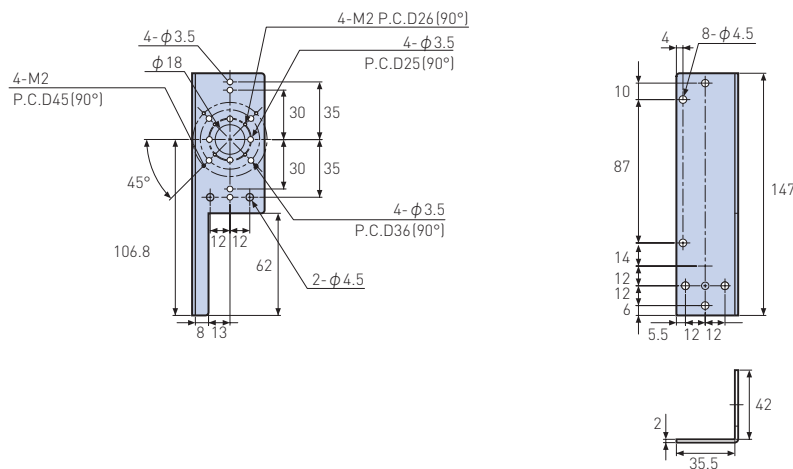

(unit: mm)