

## Multi Camera Vision Sensor MVS Series

### MVS-PM-R Color pattern matching camera unit



Direction of electronic parts

It can detect color and shape of target object.

**Application examples :**

- Inspection of electronic parts
- Inspection of position of parts for automobile
- Checking existence of some material by its color

### MVS-EM-R Measurement camera unit



Positioning of printed circuit board

It can measure distance between edges on the objects.

**Application examples :**

- Measuring diameter of parts for automobile
- Counting edges on the surface of parts
- Measuring pitch of lead frame for electronic parts

### MVS-OCR2 Color OCR camera unit



Shelf life of confection

It can inspect Date, Time and Text.

**Application examples :**

- Inspection of shelf life on the label
- Inspection of lot number on the label
- Inspection of Part number labeled on the parts for automobile

### MVS-DN-E Controller

Controller has Touchscreen for easy operation.



The controller supports up to 3 cameras

You can connect 3 different cameras to one controller



# MVS SERIES APPLICATION

MVS Series

CVS Series

MVS Series APPLICATION

MVS-PM-R/EM-R

MVS-OCR2

OPTIONS

## 1. Detecting presence of metal washer

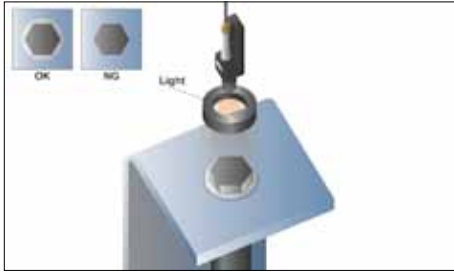

**MVS-PM-R**  
-Detect its area by color

**MVS-EM-R**  
-Measure the diameter of the washer

## 2. Checking engine spark plugs

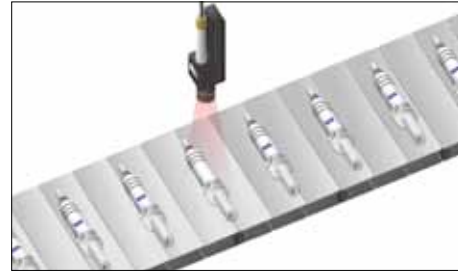

**MVS-PM-R**  
-Contour matching

**MVS-EM-R**  
-Measure its character

**MVS-OCR2**  
-Check the part number

## 3. Checking amount of paint or glue applied

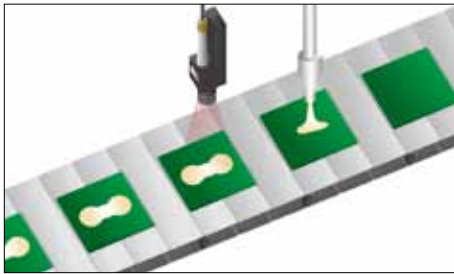

**MVS-PM-R**  
-Check its area by color

**MVS-EM-R**  
-Measure its size in X/Y

## 4. Checking engine position



**MVS-PM-R**  
-Check position by pattern matching

**MVS-EM-R**  
-Measure the distance of body - engine

## 5. Check bead of sealing rubber for continuity

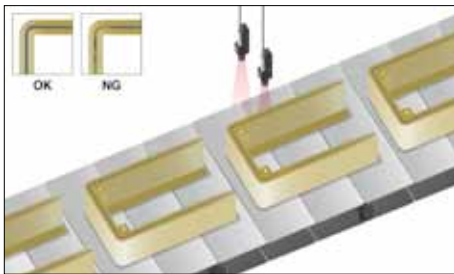

**MVS-PM-R**  
-Check color area of the rubber

## 6. Checking display of vehicle speed panel

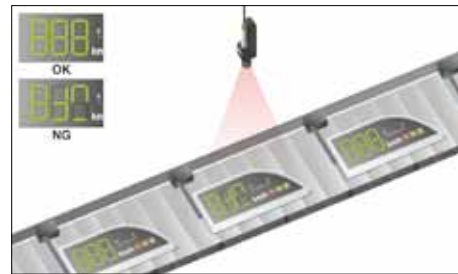

**MVS-PM-R**  
-Check color area in each part  
-It can check up to 16 parts utilizing 16 inspection windows

## 7. Checking shape of O ring



**MVS-PM-R**  
-Check shape by contour

**MVS-EM-R**  
-Measure the diameter

## 8. Checking gap between doors

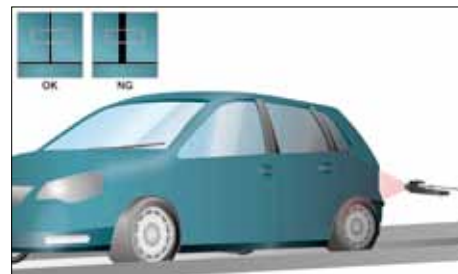

**MVS-PM-R**  
-Check area of the gap

**MVS-EM-R**  
-Measure the gap

## 9. Verifying fuse position and type in fuse panel

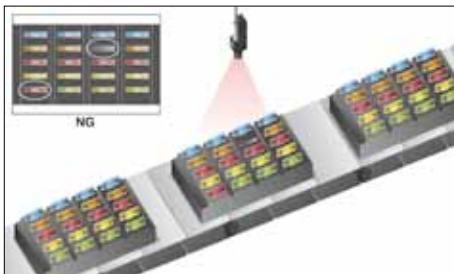

**MVS-PM-R**  
-Check color of fuse and position  
-Lighting to be mounted from side to reduce surface reflection

## 10. Checking shape of piston valve



**MVS-PM-R**  
-Check the shape by pattern matching

**MVS-EM-R**  
-Measure the dimensions

### 11. Check flame to ensure the presence of material



**MVS-PM-R**  
-Check color  
area of flame

### 12. Check LED color and parts position

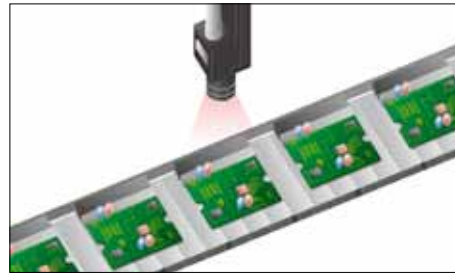

**MVS-PM-R**  
-Check parts  
position and  
area by color

### 13. Check direction of parts in emboss taping

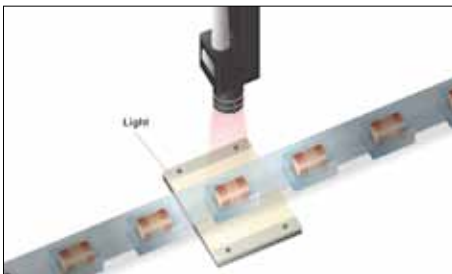

**MVS-PM-R**  
-Check the  
direction by  
color pattern  
matching

### 14. Measuring pitch of lead frame



**MVS-EM-R**  
-Measure the  
pitch in Max.,  
Min. and  
Mean

### 15. Checking the color of paint on parts

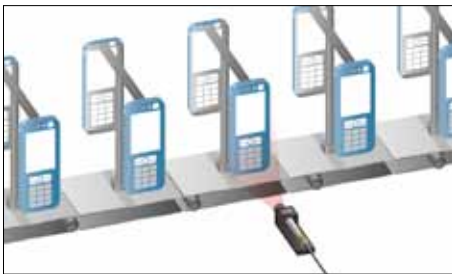

**MVS-PM-R**  
-Check for  
correct color  
accuracy and  
application

### 16. Check presence of parts in tooling machine

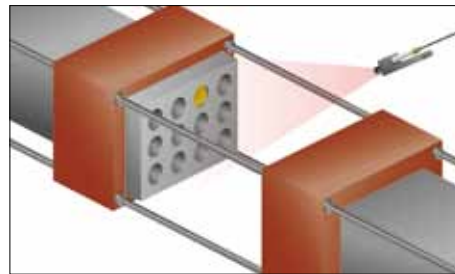

**MVS-PM-R**  
-Check the  
presence of  
parts by color  
pattern  
matching

### 17. Checking existence of paste on PWB

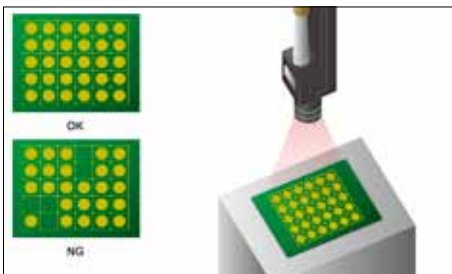

**MVS-PM-R**  
-Check  
existence of  
the paste by  
pattern  
matching

### 18. Checking surface condition of chip parts

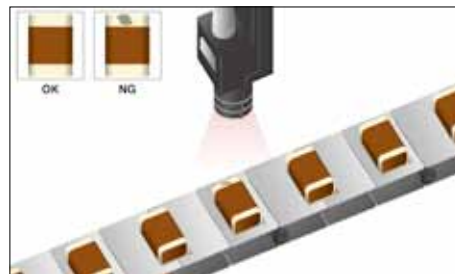

**MVS-PM-R**  
-Check stain  
area on the  
surface of the  
chip parts

### 19. Detecting misalignment of material in tooling machine

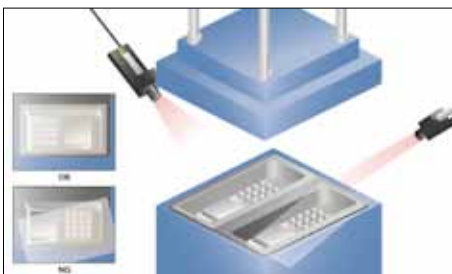

**MVS-PM-R**  
-Check  
material  
contour  
**MVS-EM-R**  
-Measure  
object  
position from  
edge

### 20. Checking shape of emboss taping

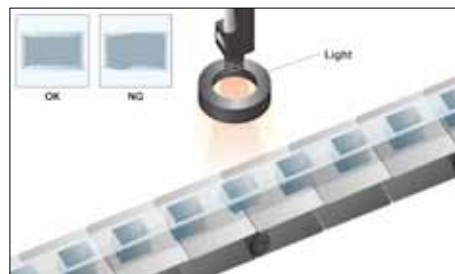

**MVS-PM-R**  
-Check its  
shape by  
contour or full  
color

21. Checking lead pitch of parts

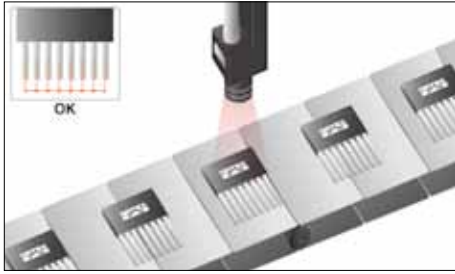

**MVS-EM-R**  
-Measure pitch of multiple leads in max., min. and mean.

22. Check printing on transistors

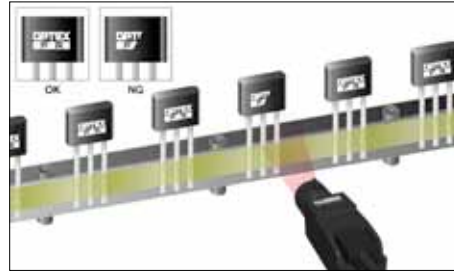

**MVS-OCR2**  
-Check the characters printed on transistors

23. Check the marking on chip parts

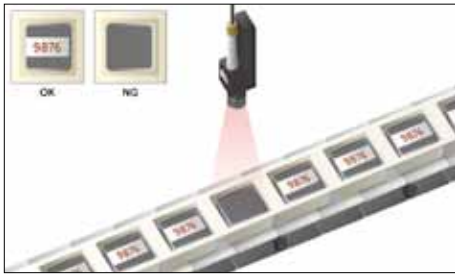

**MVS-PM-R**  
-Check existence of mark  
**MVS-OCR2**  
-Check the characters printed on the chip

24. Checking position of orientation flat



**MVS-PM-R**  
-Check the area  
**MVS-EM-R**  
-Check the distance between edges

25. Checking existence of solder balls

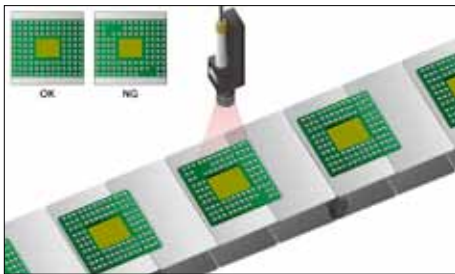

**MVS-PM-R**  
-Check color area of the solder balls by utilizing multiple inspection windows (max. 16)

26. Checking position of wafer on handling machine



**MVS-PM-R**  
-Check its position in the inspection window  
**MVS-EM-R**  
-Check the distance between edges

27. Checking wafer position in FOUP



**MVS-PM-R**  
-Check wafer position by color area utilizing multiple inspection windows (max.16)  
**MVS-EM-R**  
-Check distance between wafers

28. Checking position of reference mark on PWB glass



**MVS-PM-R**  
-Check its position by pattern matching  
**MVS-EM-R**  
-Measure distance between edges

29. Checking condition of vacuum collet tip



**MVS-PM-R**  
-Check the shape by pattern matching

30. Checking segments of LCD display



**MVS-PM-R**  
-Check its condition by contour matching

### 31. Checking shape of rubber ring



**MVS-PM-R**  
-Check its shape by pattern matching

**MVS-EM-R**  
-Measure distance between two outermost and innermost edges

### 32. Check for the presence of parts and correct order on PWB

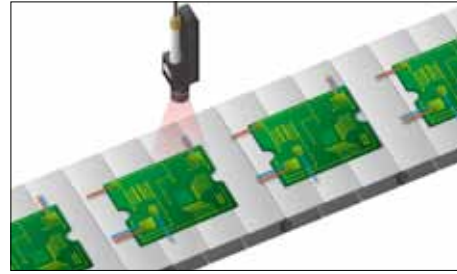

**MVS-PM-R**  
-Check color area utilizing multiple inspection windows (max. 16)

### 33. Checking lid alignment



**MVS-PM-R**  
-Multiple points on the lid are checked to determine alignment

### 34. Checking shape and printing on milk package

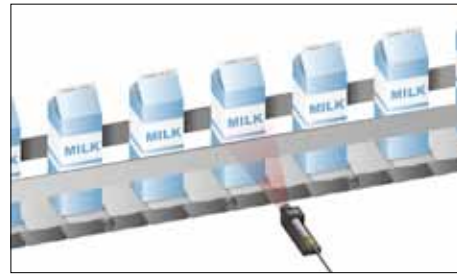

**MVS-PM-R**  
-Check the shape by its contour or other pattern matching

**MVS-OCR2**  
-Check for printing on the package

### 35. Checking shape of plastic bottles

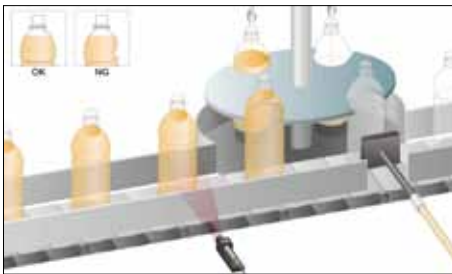

**MVS-PM-R**  
-Check the shape by contour

### 36. Checking for label on plastic bottle

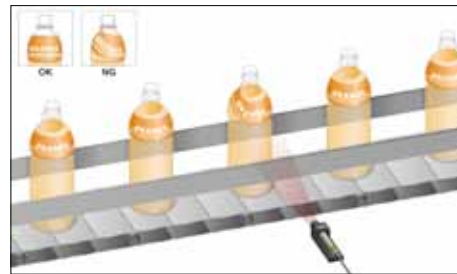

**MVS-PM-R**  
-Check its position and type by color pattern matching

**MVS-OCR2**  
-Check characters printed on label

### 37. Checking number and type of bottles



**MVS-PM-R**  
-Check for presence of each bottle by color pattern matching

### 38. Checking position and type of pills in dispenser



**MVS-PM-R**  
-Check position and type by color pattern matching

### 39. Checking level of liquid in bottle

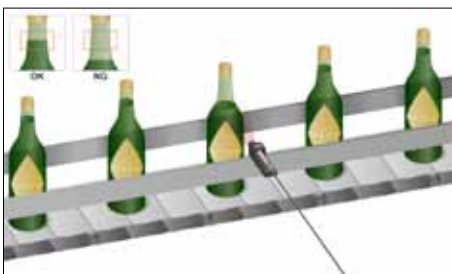

**MVS-PM-R**  
-Check color area of the liquid in the bottle

**MVS-EM-R**  
-Measure position of liquid surface in the bottle

### 40. Checking level of liquid in tube

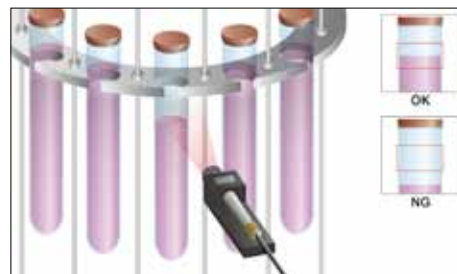

**MVS-PM-R**  
-Check color area of the liquid in the tube

**MVS-EM-R**  
-Measure position of liquid surface in the tube

**41. Checking characters printed on pouch**



**MVS-OCR2**  
-Check characters on the pouch

**42. Detecting condiments in instant food package**



**MVS-PM-R**  
-Check color area of each condiment

**43. Checking characters printed on yogurt lid**

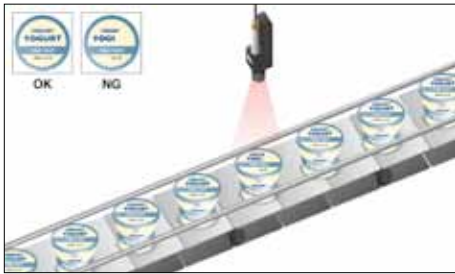

**MVS-PM-R**  
-Check characters on the lid by color pattern matching  
**MVS-OCR2**  
-Check characters on the lid

**44. Checking existence of blob or stain on a bottle cap**



**MVS-PM-R**  
-Check surface condition by stain area and color area

**45. Checking presence of label attached for ad campaign**



**MVS-PM-R**  
-Check its position by color pattern matching

**46. Checking for characters printed on package**

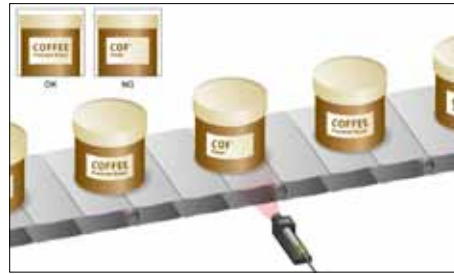

**MVS-PM-R**  
-Check character by color pattern matching  
**MVS-OCR2**  
-Check character on the package

**47. Detecting defects on bottle**

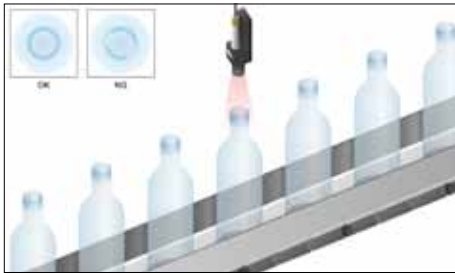

**MVS-PM-R**  
-Detect defects by checking the contour

**48. Checking position of heat sealing on pillow packaging**

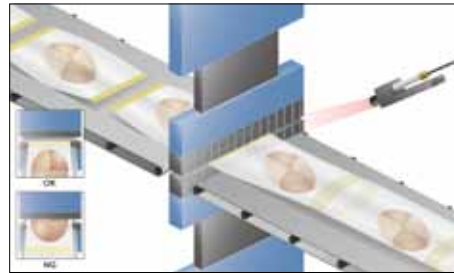

**MVS-PM-R**  
-Check the position of heat sealing area by color pattern matching

**49. Detecting lid position on the bottle**



**MVS-PM-R**  
-Check its position by color pattern matching

**50. Checking for correct order in Calendar sorting**



**MVS-PM-R**  
-Check pattern by unique characteristics of each sheet  
**MVS-OCR2**  
- Check printed characters

### 51. Checking presence and position of packing tape

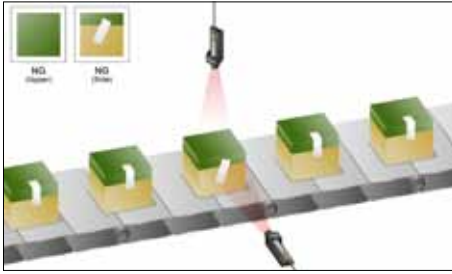

**MVS-PM-R**  
-Check the position by color pattern matching

### 52. Sorting objects by shape

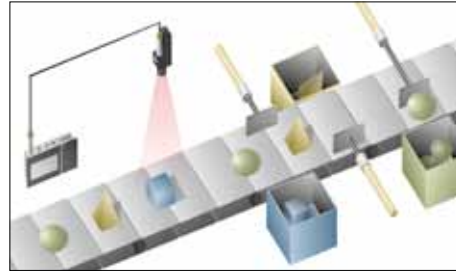

**MVS-PM-R**  
-Check and sort objects by shape

### 53. Checking position of printing material



**MVS-PM-R**  
-Check deviation of the mark from original position

**MVS-EM-R**  
-Measure position of the mark

### 54. Measure width of sheet material

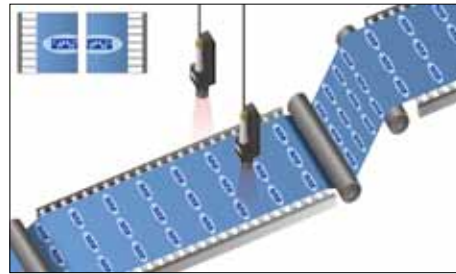

**MVS-PM-R**  
-Check deviation of the edge from original position

**MVS-EM-R**  
-Measure position of the edge

### 55. Measuring dimension of object

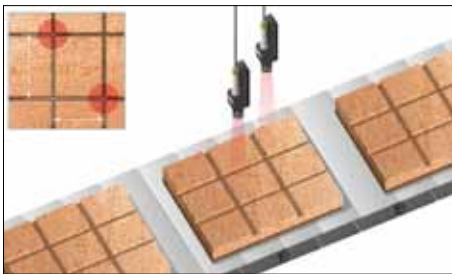

**MVS-PM-R**  
-Measure distance between two edges

### 56. Measuring thickness of object

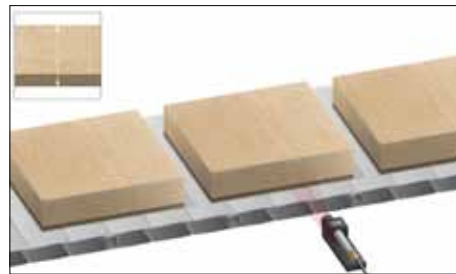

**MVS-EM-R**  
-Measure distance between two edges

### 57. Checking size of rubber bank



**MVS-PM-R**  
-Check area of the rubber

**MVS-EM-R**  
-Measure distance between two edges of rubber

### 58. Checking shape and surface condition of plastic parts



**MVS-PM-R**  
-Check the shape by contour and check the surface condition by stain area and color area

## Advanced Technology High speed vision processing and cost savings

### PM EM OCR Original LSI with CPU integrated ECO-Engine: OPTimum CPU Ver.5

The MVS features an Optex original design LSI with CPU integrated, we were able to integrate the vision process engine into the camera unit. This solution provides high speed image processing and accurate inspection for a variety of applications. Each camera processes the image internally and transmits the result to the controller.



### PM EM OCR No change in response speed when operating multiple cameras Three Cameras inspect independently

We utilized a new technology in the MVS that features low heat generation and low power dissipation. This concept was originally developed for the CVS series as an all-in-one design, the same technique was carried over to the MVS. There is no change in the response time when multiple cameras are used. The all-in-one design allows the camera to operate independent from the controller.

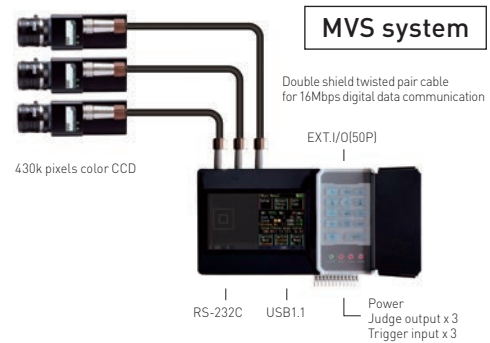

### PM EM OCR Integrated system technology High Performance, Easy Installation and Low Cost

The controller has a built-in touchscreen interface, full color display and ten-key input panel. A power supply for control of the external lighting is also integrated into the controller. Simply connect the cameras and lights to the controller. There is no need for a console, external monitor or a separate power supply for lighting.



### PM EM OCR Support is available from LED lighting to training

Lighting is the single most important factor to capturing a good quality image for inspection. Optex FA offers a complete selection of lighting options. We can provide customer support for the selection of lighting, lenses, and training.

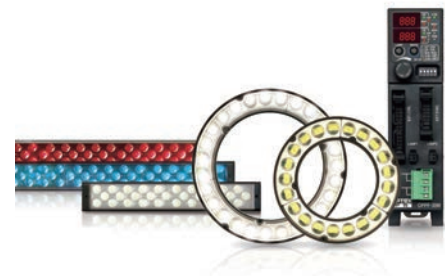



## **PM EM** Up to 16 inspections can be done at the same time with one Camera **16 Inspection windows are available for each Camera**

Each Camera can have a maximum of 16 inspection windows in one Bank of memory. Each inspection window can be set to inspect a different feature based on 6 inspection functions. The inspection judgment output for each inspection window can be output through the 50 pin I/O connector.



## **OCR** Up to 4 inspection windows

The parameters for each inspection window can be individually set.

Up to 2 Forms of each Date and Time are available for one window and up to 4 Forms of strings are available(max. total of 4 Forms).

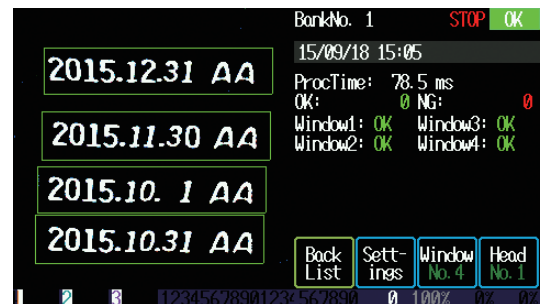

## **PM EM OCR** Quick change over **32 Banks are available for one Camera**

You can remotely select the bank to use by using a controller, PLC or the RS-232C I/F. The setup parameters for each bank are stored in memory and can be recalled when the product is run again.



## **PM EM OCR** Lighting control without the need of a separate power supply **Controller has LED lighting control built in**

Support for a total of three LED lights(12VDC, 24W total)is available.

The output connector for the power source is a quick connect/disconnect type.

The intensity level for each light can be adjusted separately.



## For stable inspection and better process yield 7 functions are available

### PM EM OCR Continuous capture

When the camera checks the image it will automatically check up to 5(EM-R) or 6 images(PM-R) or 8 images(OCR2), looking for a good reading. This insures stable operation if the trigger is not stable or the position of the object changes slightly. If the result is found to be OK the inspection will stop prior to reaching the maximum number of inspections.

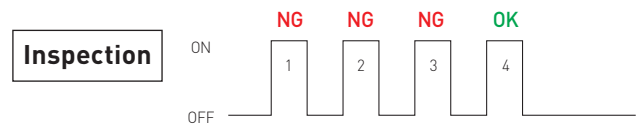
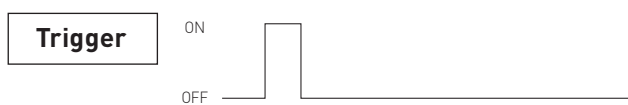

### PM EM OCR Variable shutter speed

When the camera is checking image using the Continuous Capture feature the shutter speed will automatically be adjusted up to +36% ~ -24%(PM-R/EM-R) or +/-12% (OCR2). This compensates for changes in the lighting.

### PM EM OCR Search function

The images is searched not only in the X and Y direction but it also can be rotated up to +/- 180 degrees (PM-R/OCR2) or +/- 45 degrees(EM-R). This is useful when the position or orientation of the object changes.

### PM Scaling up/down

When the camera is checking the image using the Continuous Capture feature the image will automatically be scaled Up/Down by up to +/-6%. This compensates for changes in the distance between the camera and object.

### PM EM Trouble Shoot

**Troubl Shooting** button leads you to the Trouble Shooting menu. From this menu, you are able to view what corrections need to be done.

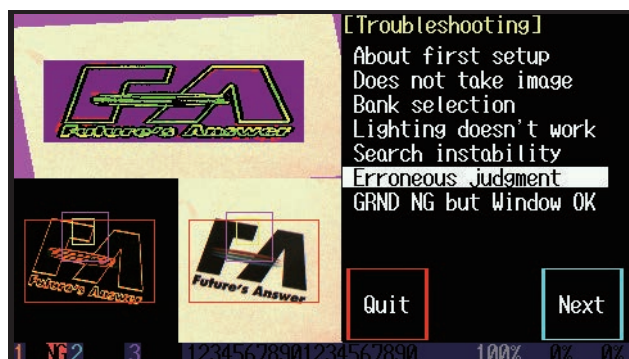

### PM EM OCR Help function

**?** button on the ten-key panel shows what the parameter means and what adjustments can be done.

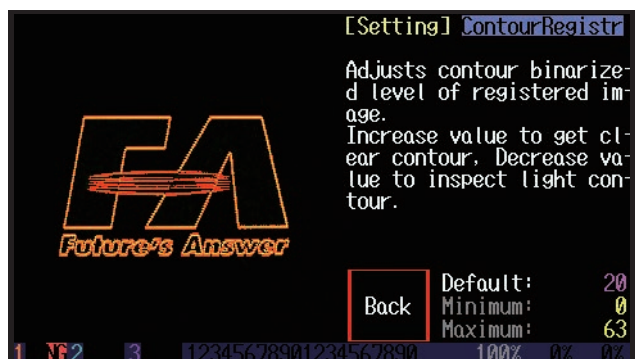

# PM OCR Dark Compensation (OCR2 : Illuminance Correction)

For reliable inspection of color, the hue of each pixel is calculated. This function insures that captured images are stable even with variations in lighting or when the distance to the target changes.

### When the light is from the top

The MVS calculates the hue of each pixel so it can get a homogenous color for each pixel. Regular vision sensors simply adjust the brightness so the upper part is brighter than the lower part.



### When a bright ambient light is present

The MVS can get a homogenous color for each pixel even if the object has an area which is brighter due to external ambient light.

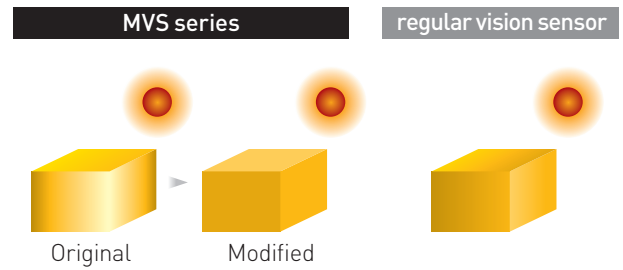

### When the distance varies

The Dark Compensation function is effective when the object distance varies and its brightness changes.

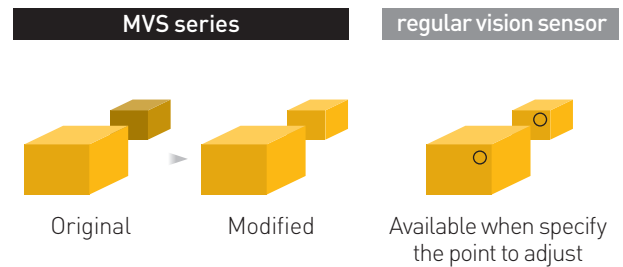

### When the object is glossy

The Dark Compensation function helps to reduce bright spots on glossy surfaces.

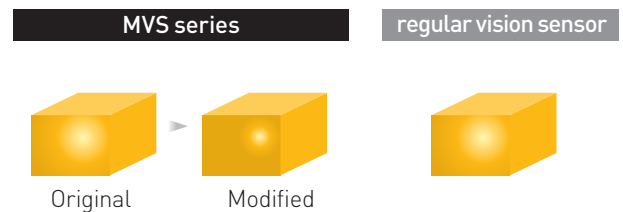

## PM EM Simply follow the explanation on the display Fast and easy "SETUP Menu"

Concept : No operating manual required



button leads you to the SETUP menu where each step is clearly described.

Following is example of MVS-PM SETUP Menu



Backlit buttons show which are active to assist in Setup and adjustment. Help functions can be accessed at any time by pressing the "?" button.

1. Touch[Setup]button



2. Select "Bank" and "Trigger mode"

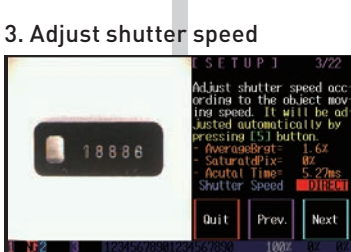

4. Adjust brightness and direction of the image



5. Storing captured image



6. Select Color mode or Black and White mode



7. Determine search area and its function



8. Setup inspection windows



9. Setup inspection function

Select function from Stain/Color Area/Full Color/Differential/Contour/Color Shape



10. Touch[Finish]to exit setup menu



## OCR Easy Setting and Processing 3 - Step - setup

What you have to do is just proceed setting parameters as shown on the display one by one. This helps you not to forget setting some parameters and reduce setting wrongly. It's just 3 steps you have to go through settings that is much more simple than conventional MVS-OCR. You can reduce time for installation as well.

STEP 1

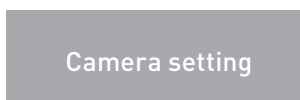

STEP 2



STEP 3

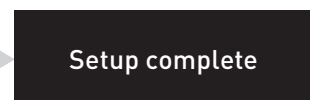
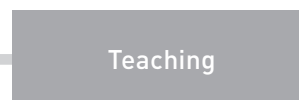

## Inspection for Color, Flaw, Blob, Shape, etc. 6 inspection modes are available

### Stain

The camera compares the differential ratio of the stored master image with the differential result of the target image to determine the Stain value. When this value exceeds the upper limit or is less than the lower limit, it is defined as NG. This is used to detect the presence of stain (flaws) on the surface of metal objects or defects in plastic materials.

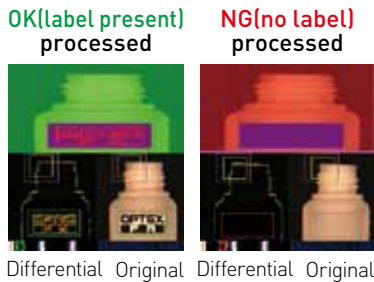

### Contour

The camera compares the contour of the stored differential master image with the contour of the target object. It counts the number of pixels that do not match the Target contour to determine the Contour value (Lack of pixels). It counts the number of pixels outside of the Target contour area (background) which have the selected color to determine the Stain value.

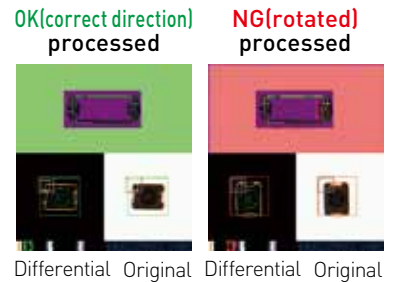

### Differential

The camera compares the stored differential master image with the target object. If the difference exceeds the threshold it is defined as NG. This function is used to inspect metal parts with uneven lighting. It is not good for detecting color or its depth.

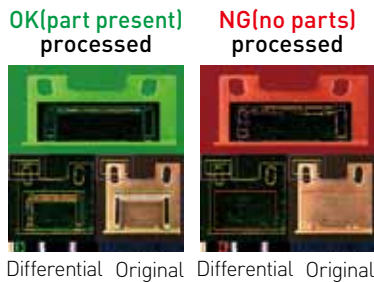

### Color Shape

The camera inspects the shape of the area that contains the selected color. It counts the number of pixels that have a different color in this area to determine the Contour value (Lack of pixels). It counts the number of pixels outside of the area (background) which have the selected color to determine the Stain value.

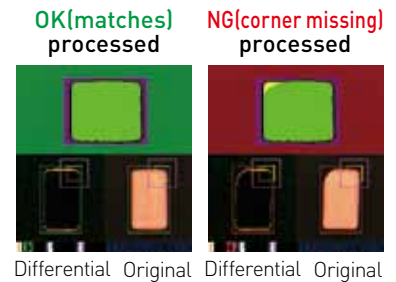

### Color Area

The camera calculates the ratio of the number of pixels that have the selected color to all the pixels in the inspection window. When it exceeds the upper limit or is less than the lower limit, it is defined as NG.

This is used to detect color differences, especially when the color is not stable and that there is no need to detect object shape.

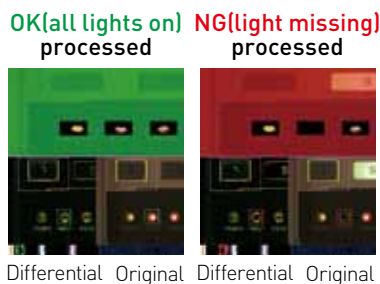

### Full Color

The camera will compare the difference between the full color image of the target and the stored image. If the sum of the difference exceeds the threshold value it is defined as NG.

This is used to inspect color and depth of pictures and prints under stable lighting.

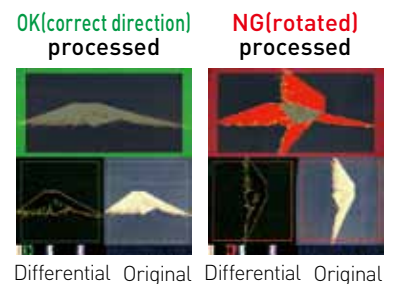

## Measurement of Inner / Outer Dimension, Edge position, Counting edges, etc.

### 6 inspection modes are available

#### Outer Dimension

The camera measures the distance between the two outermost edges. Choose between the longest, shortest or the mean value in the selected inspection window.

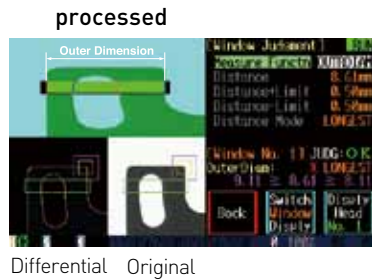

Differential Original

#### Inner Dimension

The camera measures the distance between the two innermost edges. Choose between the longest, shortest or the mean value in the selected inspection window.

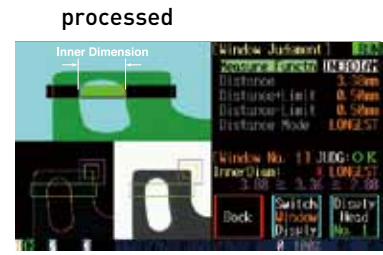

Differential Original

#### Position

Measures the distance between two edges in two different inspection windows. This function is useful for detecting the displacement of edges. Choose between the longest, shortest or the mean value in the selected inspection window.



Differential Original

#### Number of Edges

The camera counts the number of edges in the inspection window. Choose the edges to count based on the transition of light to dark, dark to light or all of the edges. In the processed image, a red line means a light to dark transition and a blue line means dark to light.

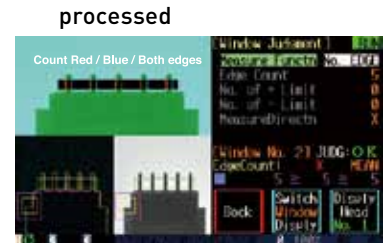

Differential Original

#### Multiple Edges

The camera measures the distance between edges in the inspection window. Choose the edges of a light part (blue line to red line) or a dark part (red line to blue line). It judges by longest limit, shortest limit or the mean value.



Differential Original

#### Center Pitch

The camera measures the pitch between the centers of the edges in the selected inspection window. It judges by longest limit, shortest limit or the mean value.



Differential Original

# MVS-OCR2 FEATURE

MVS Series

## Achieved 8 times better resolution **NEW**

### High resolution system enables accurate print inspection

With mega pixel C-MOS image sensor, it achieved accurate print inspection by better character recognition.

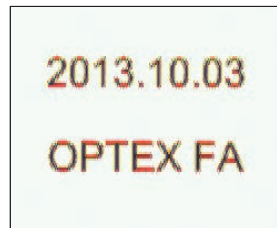

Conventional MVS-OCR

The camera can capture clear image



MVS-OCR2

CVS Series

### You can get bigger FOV (Field Of View)

With better resolution, you can set around 2 times bigger FOV.

Print inspection of long printing in wide area is available

Example of print inspection on cardboard box

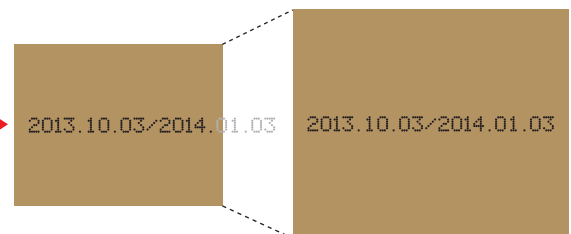
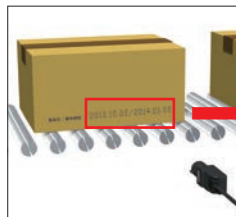

MVS-OCR  
Long print can't be in the FOV

MVS-OCR2  
Long print can be in the FOV thanks to better resolution.

MVS Series APPLICATION

MVS-PM-R/EM-R

### Clear clipping out of the characters by new algorithm

### It clips out of the characters clearly even if the lighting is uneven **NEW**

New algorithm achieved clipping out of the characters under uneven or unstable lighting.



Original

Extracts contour of characters clearly

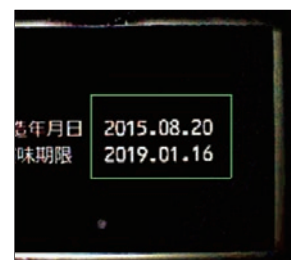

Processed

MVS-OCR2

OPTIONS

### Character recognition feature of MVS-OCR2

MVS-OCR2 compares captured image with internal dictionary and choose most alike character.

Then, it compares the recognized characters with expected characters. When all characters are correct, it outputs "OK". Otherwise, "NG" (No Good).

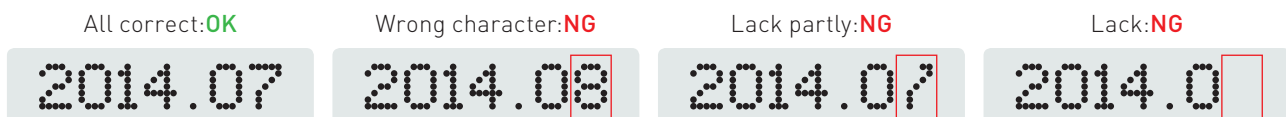

## Recognizes various printer fonts

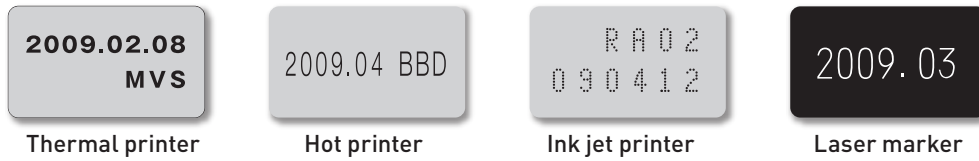

## Change the image direction

The image direction for each bank can be set. This makes it possible to read reverse printed characters such as printing on the opposite side of a transparent sheet.

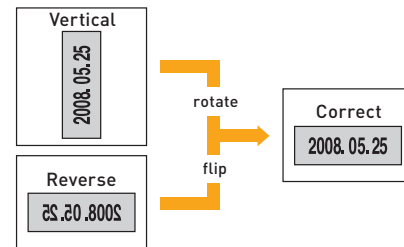

## Functions to prevent miss recognition for stable inspection

We installed useful functions that are created based on our long experience in print inspection industry.

### Warning (multiple objects run stucked) **NEW**

When the objects run stucked side by side, the photo sensor outputs only once and the conventional OCR sensor won't check second one. MVS-OCR2 has warning function by checking trigger signal length to detect this problem.



### Focus Monitor **NEW**

It is difficult to adjust focus of the camera if you are not get use to it. MVS-OCR2 has "Focus Monitor" function a kind of level gauge that shows how much the camera focuses at the point to be adjusted. It will be very easy to adjust by checking visualized level bar.

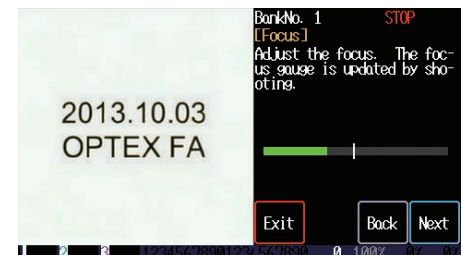

Focus Monitor display

### Auto Calendar

MVS-OCR2 compares the date and hour with internal calendar which automatically runs so you don't have to re-setup the characters to check every time.

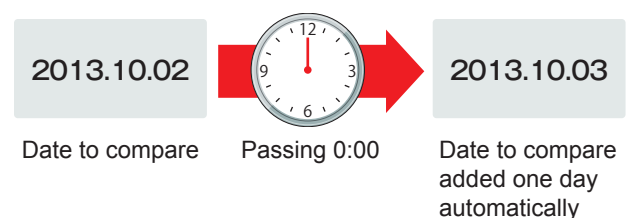



## Matching tolerance per character

The matching tolerance for each character can be set (ex. the numbers "6" and "8" are very close in shape and need to be checked closely).

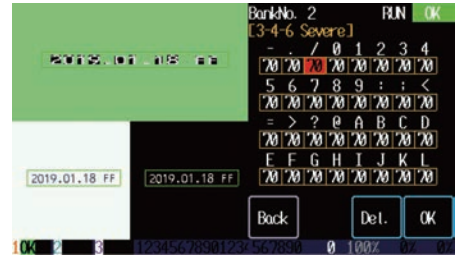

## OCR regardless of color

The MVS-OCR2 is able to detect characters regardless of the color of the background.

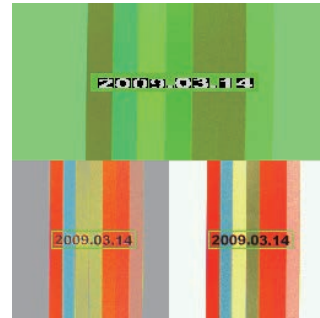

## Search function

The MVS-OCR2 is able to search in both the X and Y directions, it also can do a rotational search of +/- 0~180 degrees by pattern matching.

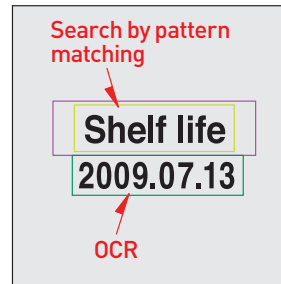

## User defined characters

The MVS-OCR2 can recognize lower case letters and special symbols defined by the user dictionary.

For example it can be used to distinguish between "H" and "M" when the font that is used makes these letters hard to distinguish.



## Code recognition

It can recognize Code of Month/Date/Hour/Minute.

Example: "CA0 H" → "March 15th, 7 O'clock"

Conversion list example

You can modify on the controller.

Month	Date			Hour	Minute						
1 A	1 AA	11 AK	21 AU	0 A	12 M	0 A	C	E	G	I	K
2 B	2 AB	12 AL	22 AV	1 B	13 N	1 A	C	E	G	I	K
3 C	3 AC	13 AM	23 AW	2 C	14 O	2 A	C	E	G	I	K
4 D	4 AD	14 AN	24 AX	3 D	15 P	3 A	C	E	G	I	K
5 E	5 AE	15 AO	25 AY	4 E	16 Q	4 A	C	E	G	I	K
6 F	6 AF	16 AP	26 AZ	5 F	17 R	5 B	D	F	H	J	L
7 G	7 AG	17 AQ	27 BA	6 G	18 S	6 B	D	F	H	J	L
8 H	8 AH	18 AR	28 BB	7 H	19 T	7 B	D	F	H	J	L
9 I	9 AI	19 AS	29 BC	8 I	20 U	8 B	D	F	H	J	L
10 J	10 AJ	20 AT	30 BD	9 J	21 V	9 B	D	F	H	J	L
11 K			31 BE	10 K	22 W						
12 L				11 L	23 X						

\*This table is just for showing an example.

# WORKING DISTANCE vs. FIELD OF VIEW

Camera Working Distance L (mm) CCTV Lens

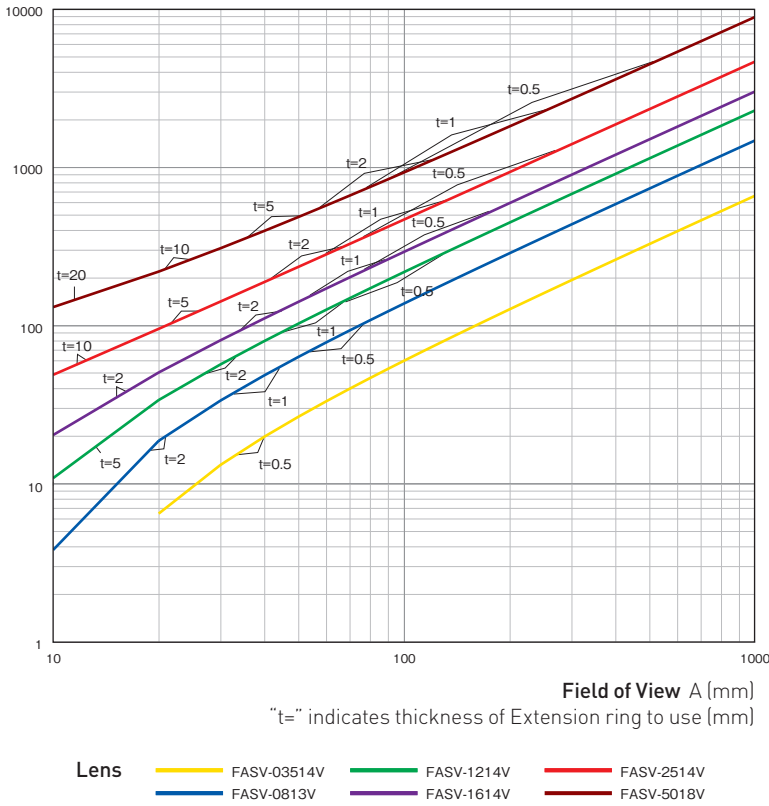

## How to utilize the graph

1. Determine Working distance (L) and Field of view (A).
2. Choose the appropriate lens and extension ring according to the graph.

PM EM

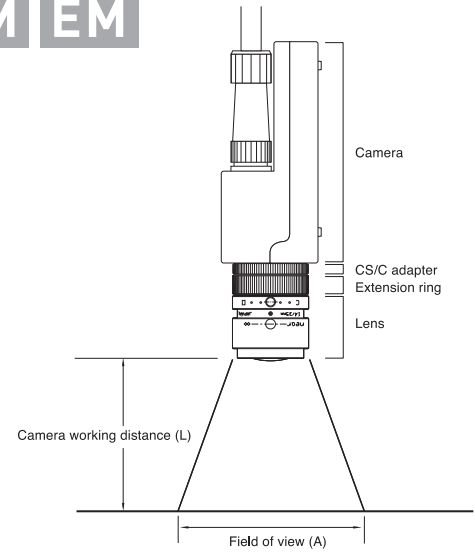

Camera Working Distance L (mm) Macro Lens for Mega-Pixel

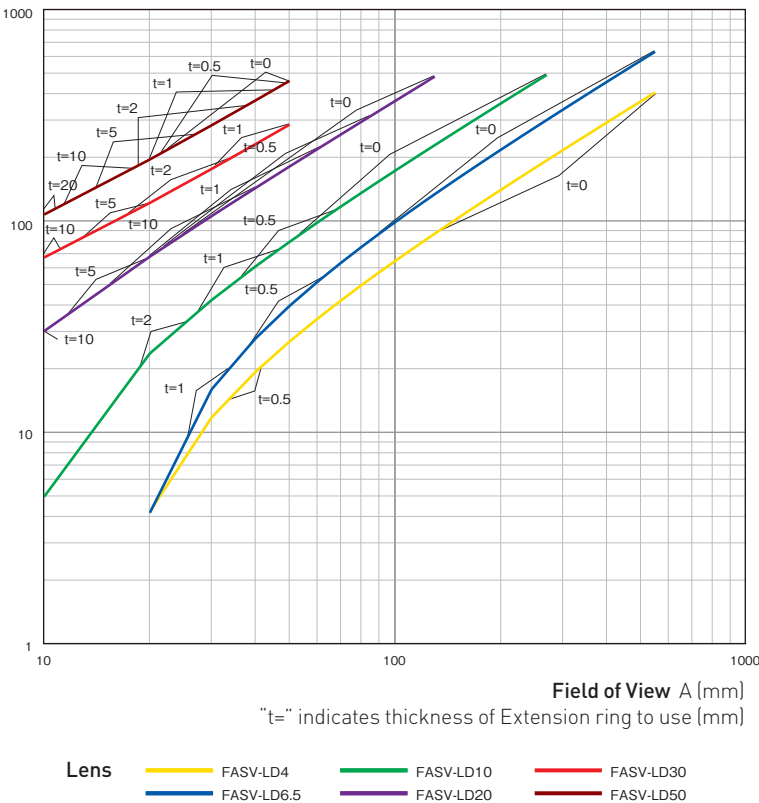

OCR

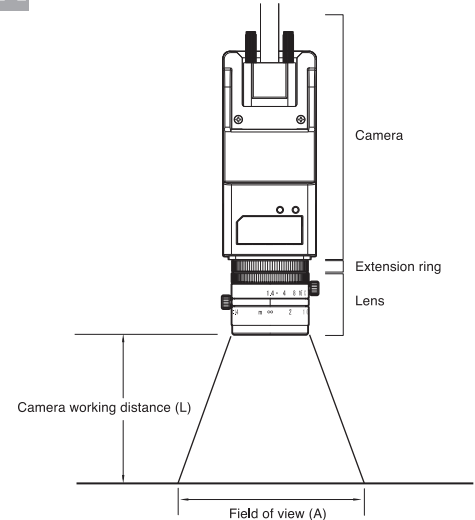

# SYSTEM PART NUMBERS

## Camera unit



**Model No.** : MVS-PM-R / MVS-EM-R  
 Image sensor : CCD(color)  
 Capture mode : Color/Monochrome



**Model No.** : MVS-OCR2  
 Image sensor : CCD(color)  
 Capture mode : Color/Monochrome

\*lens is not included. Please order separately

## Camera cable

- MVS-C2S : 2M Cable
- MVS-C5S : 5M Cable
- MVS-C5E : 5M Extension Cable
- MVS-C5SR : 5M Robotic Cable
- MVS-C5ER : 5M Extension Robotic Cable
- MVS-C5W : 5M Cable with wiring for light (need MVS-LC05)
- MVS-C2S-OCR2 : 2M Cable
- MVS-C5S-OCR2 : 5M Cable

## Controller



**Model No.** : MVS-DN-E  
 Camera No : Max 3  
 I / F : Touch panel display,  
 Ten-key  
 Ethernet

\*PNP output type is MVS-DP-E

## CCTV Lens (C mount)



**Model No.** : FASV-03514V  
 Focal Length : 3.5mm  
 F No. : F1.4  
 Filter size : -



**Model No.** : FASV-0813V  
 Focal Length : 8mm  
 F No. : F1.3  
 Filter size : M27 P0.5



**Model No.** : FASV-1214V  
 Focal Length : 12mm  
 F No. : F1.4  
 Filter size : M27 P0.5



**Model No.** : FASV-1614V  
 Focal Length : 16mm  
 F No. : F1.4  
 Filter size : M27 P0.5



**Model No.** : FASV-2514V  
 Focal Length : 25mm  
 F No. : F1.4  
 Filter size : M27 P0.5



**Model No.** : FASV-5018V  
 Focal Length : 50mm  
 F No. : F1.8  
 Filter size : M30.5 P0.5

## Macro Lens for Mega-pixel (C mount)



**Model No.** : FASV-LD4  
 Focal Length : 4mm  
 F No. : F4.16  
 Filter size : M27 P0.5



**Model No.** : FASV-LD6.5  
 Focal Length : 6.5mm  
 F No. : F6.51  
 Filter size : M30.5 P0.5



**Model No.** : FASV-LD10  
 Focal Length : 10mm  
 F No. : F10.27  
 Filter size : M27 P0.5



**Model No.** : FASV-LD20  
 Focal Length : 20mm  
 F No. : F20.74  
 Filter size : M27 P0.5



**Model No.** : FASV-LD30  
 Focal Length : 30mm  
 F No. : F30.01  
 Filter size : M27 P0.5



**Model No.** : FASV-LD50  
 Focal Length : 50mm  
 F No. : F48.46  
 Filter size : M30.5 P0.5

## Polarizing filter



**Model No.** : FASV-PL255-RS  
 size : M25.5 P0.5



**Model No.** : FASV-PL270-RS  
 size : M27 P0.5



**Model No.** : FASV-PL305-RS  
 size : M30.5 P0.5

## IR cut filters



Model No. : FASV-IR270  
size : M27 P0.5



Model No. : FASV-IR305  
size : M30.5 P0.5

## Extension ring set

Model No. : FASV-EXR-LT2  
5 piece set



## I/O Connector cable

MVS-C310 : 3m IEEE1284 half pitch 50p



## Touch panel protective sheet

MVS-TP

## External light



Model No. : OPR-S55-28W  
Method : Direct ring  
Spec : White LED/  
DC12V, 5.1W  
Cable : 500mm



Model No. : OPB-5015W2-B/  
OPB-10015W2-B/  
OPB-15015W2-B  
Method : Direct bar  
Spec : White LED/  
bracket installed  
DC12V, 5.1W  
Cable : 500mm

## Filters for light

PL-OPR-S55-28 : Polarizing filter for OPR-S55-28  
DF80-OPR-S55-28 : Diffuse filter (80%) for OPR-S55-28

PL-OPB-5015 : Polarizing filter for OPB-5015W2-B  
DF80-OPB-5015 : Diffuse filter (80%) for OPB-5015W2-B  
DF-OPB-5015 : Diffuse filter (60%) for OPB-5015W2-B

PL-OPB-10015 : Polarizing filter for OPB-10015W2-B  
DF80-OPB-10015 : Diffuse filter (80%) for OPB-10015W2-B  
DF-OPB-10015 : Diffuse filter (60%) for OPB-10015W2-B

PL-OPB-15015 : Polarizing filter for 15015W2-B  
DF80-OPB-15015 : Diffuse filter (80%) for 15015W2-B  
DF-OPB-15015 : Diffuse filter (60%) for 15015W2-B

## Light holder

OPAU-150A : Mounting bracket accessory for use with OPR-S55-28W

## Mounting bracket for light

BKT-MVS-OPR : Mounting bracket for OPR-S55-28W



BKT-MVS-OPDB-01/BKT-MVS-OPDB-01-20  
BKT-MVS-OPDB-02

Mounting bracket for OPB-5015W2-B/  
OPB-10015W2-B/OPB-15015W2-B

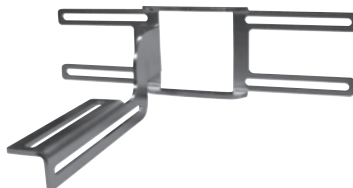

## Cable for light

MVS-LC05 : Controller to lighting connection cable, 500mm length



OP-CB1-2 : 2m Extension cable for light  
OP-CB1-3 : 3m Extension cable for light  
OP-CB1-5 : 5m Extension cable for light

# DIMENSIONS

## Camera unit

Model No. : MVS-PM-R, MVS-EM-R

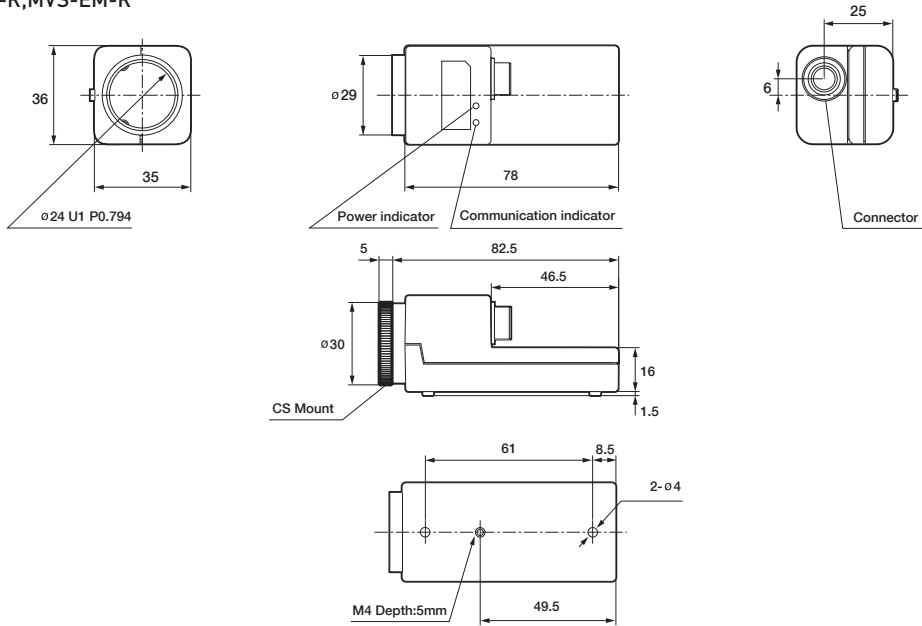

Model No. : MVS-OCR2

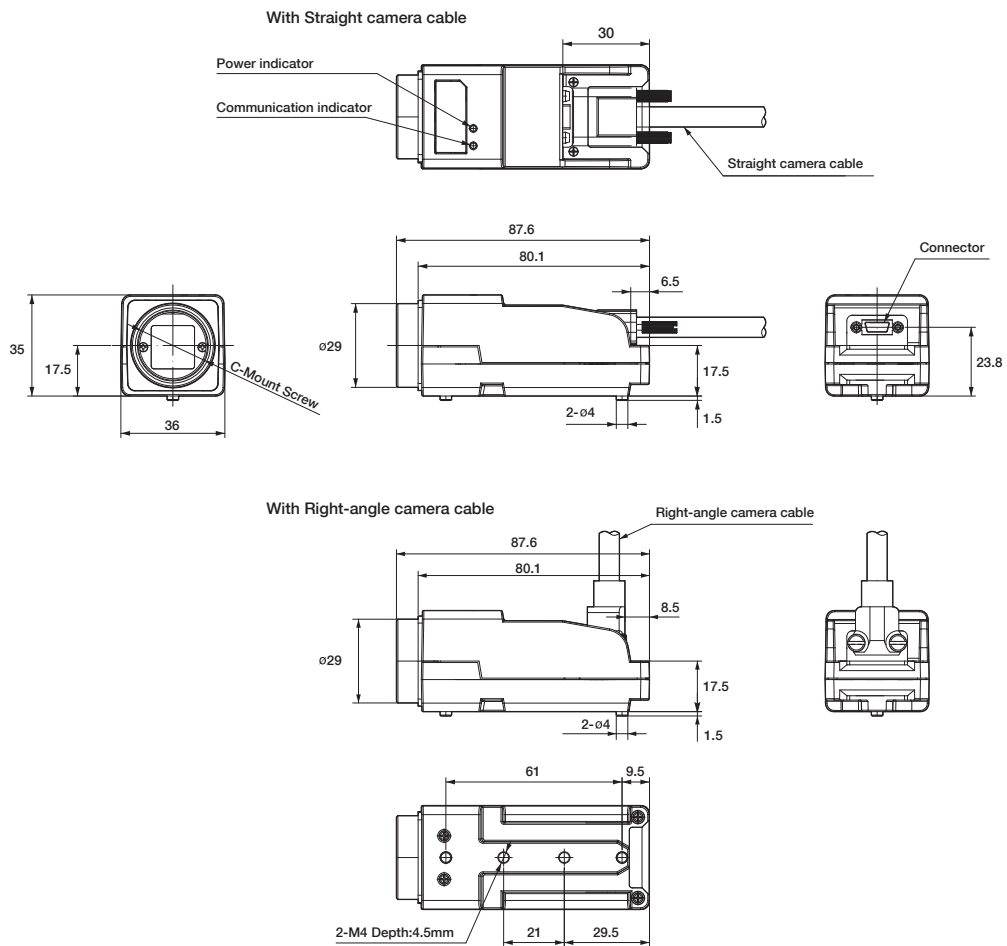

### Mounting bracket

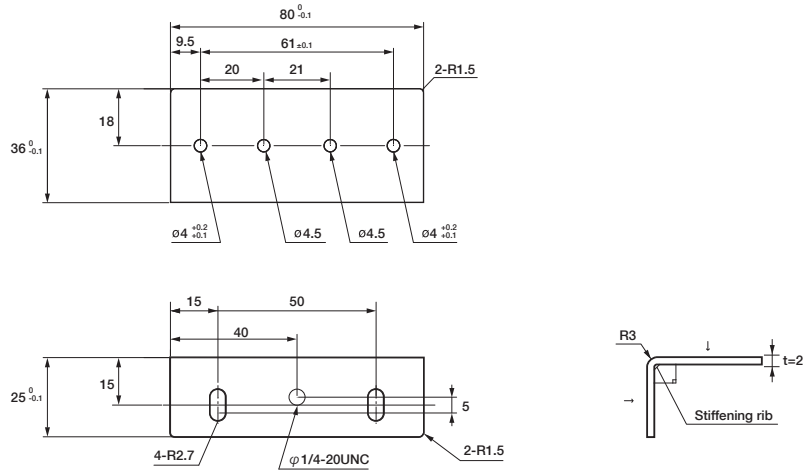

## Controller

Model No. : MVS-DN-E

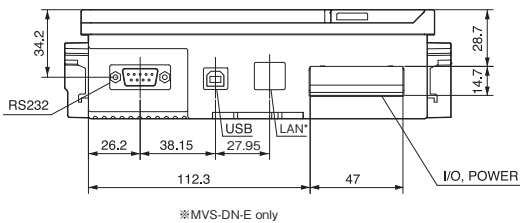
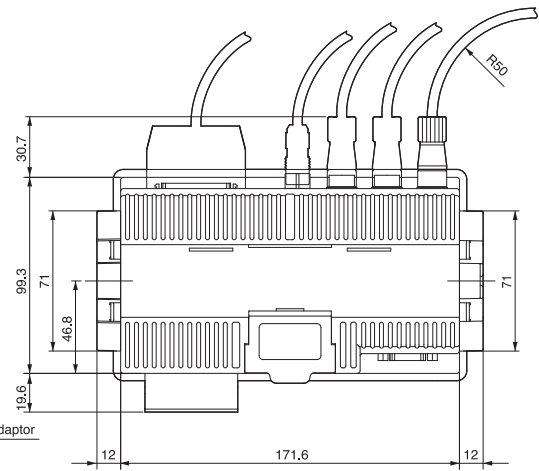
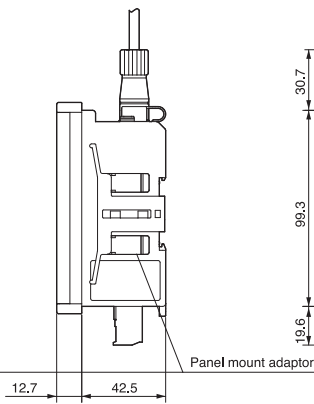
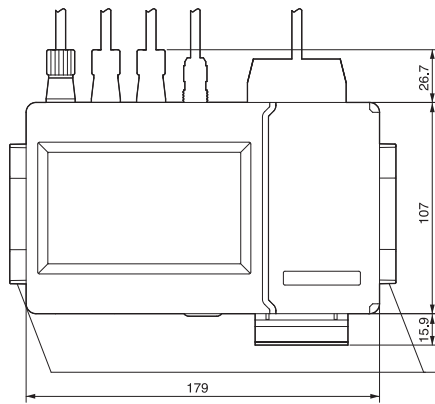
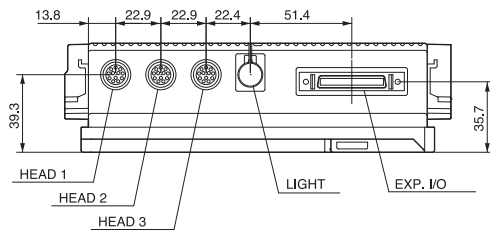

\*MVS-DN-E only

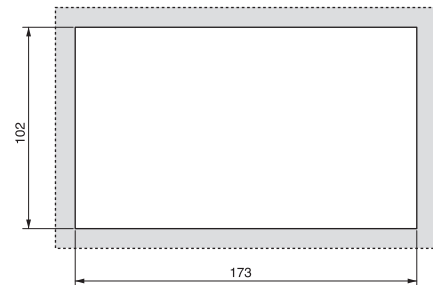

Recommended opening for mounting

## CCTV Lens (C mount)

Model No. : FASV-03514V  
Focal Length : 3.5mm

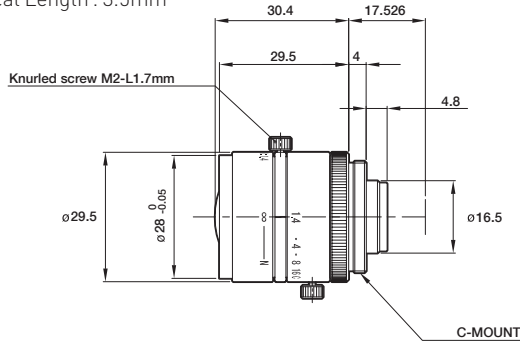

Model No. : FASV-0813V  
Focal Length : 8mm

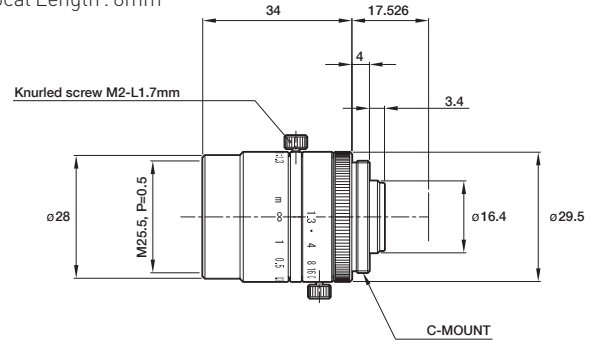

Model No. : FASV-1214V  
Focal Length : 12mm

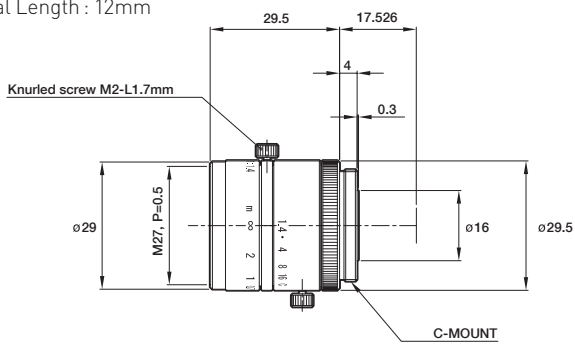

Model No. : FASV-1614V  
Focal Length : 16mm

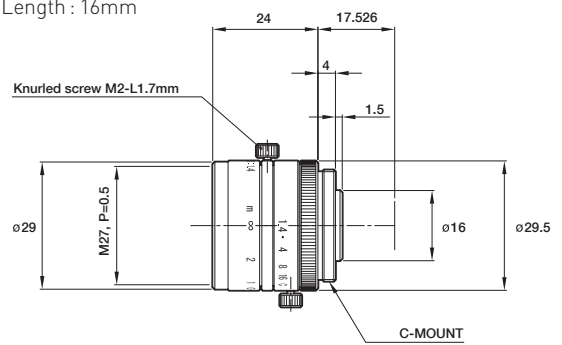

Model No. : FASV-2514V  
Focal Length : 25mm

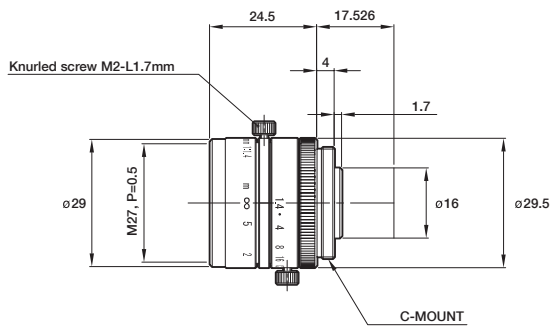

Model No. : FASV-5018V  
Focal Length : 50mm

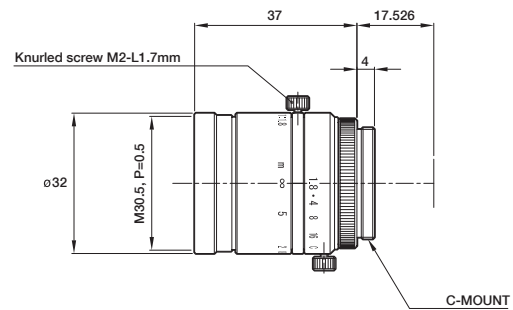

## Extension ring set

Model No. : FASV-EXR-LT2

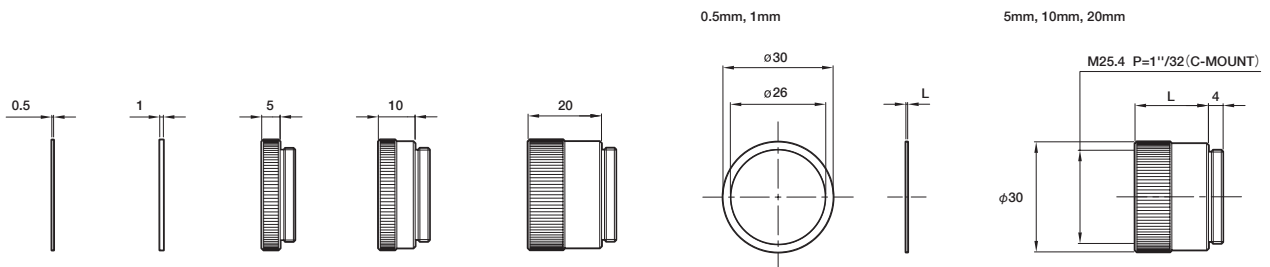

## Macro Lens for Mega-pixel (C mount)

Model No. : FASV-LD4

Focal Length : 4mm

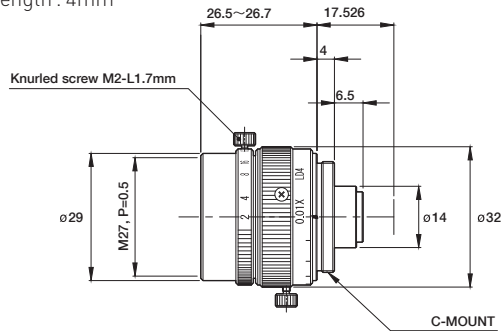

Model No. : FASV-LD6.5

Focal Length : 6.5mm

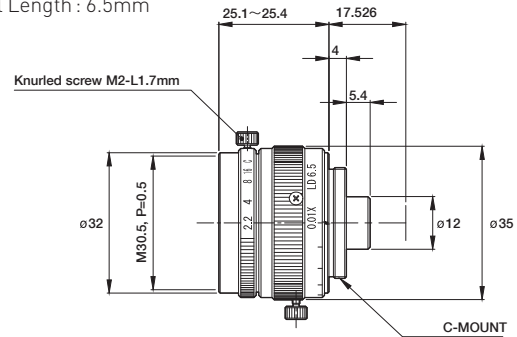

Model No. : FASV-LD10

Focal Length : 10mm

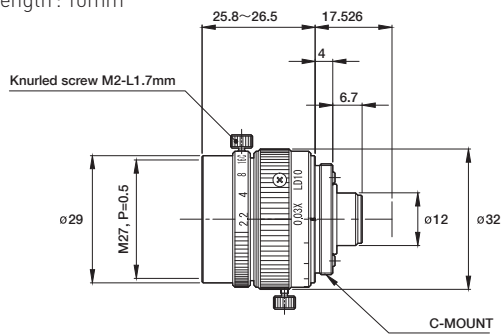

Model No. : FASV-LD20

Focal Length : 20mm

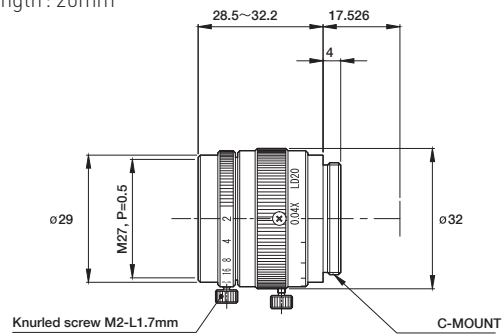

Model No. : FASV-LD30

Focal Length : 30mm

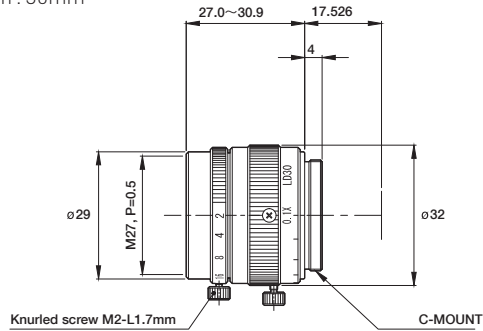

Model No. : FASV-LD50

Focal Length : 50mm

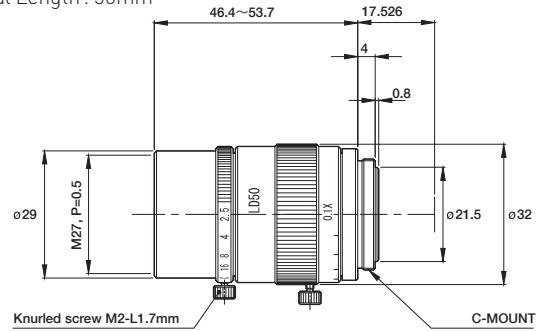

## Polarizing filter

Model No. : FASV-PL255-RS

(A) size : M25.5 P0.5

Model No. : FASV-PL270-RS

(A) size : M27 P0.5

Model No. : FASV-PL305-RS

(A) size : M30.5 P0.5

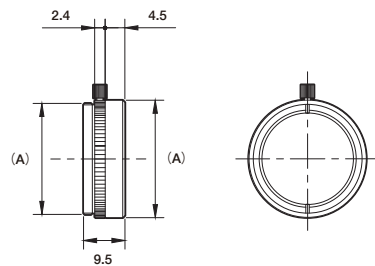

## IR cut filters

Model No. : FASV-IR270

(A) size : M27 P0.5

Model No. : FASV-IR305

(A) size : M30.5 P0.5

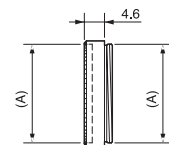



## External light

Model No. : OPR-S55-28W

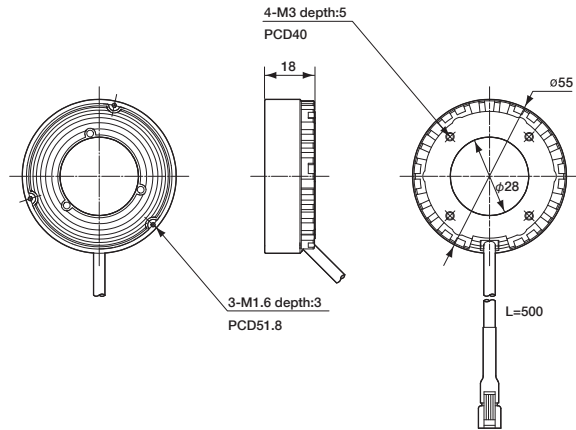

Model No. : OPB-10015W2-B (with bracket installed)

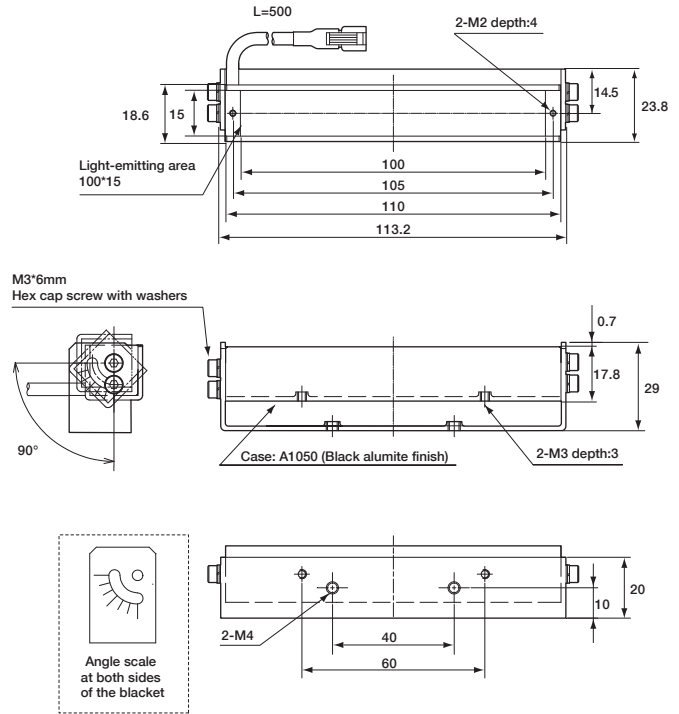

## Mounting bracket for light

Mounting bracket for OPR-S55-28W

Model No. : BKT-MVS-OPR

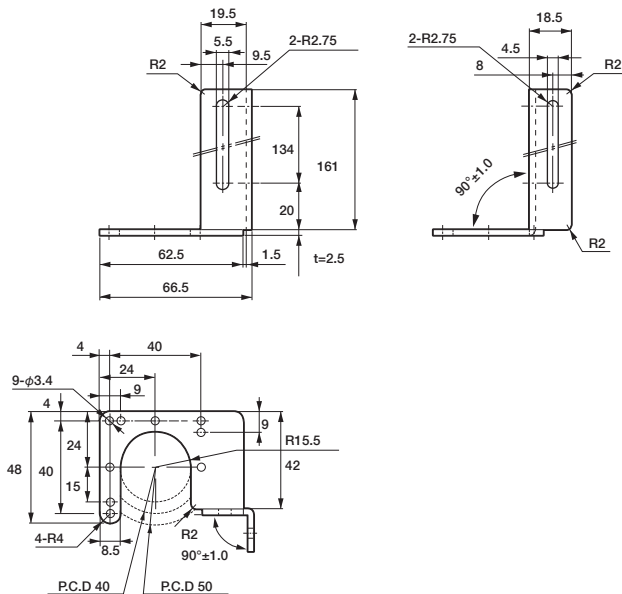

Model No. : BKTS-MVS-OPR

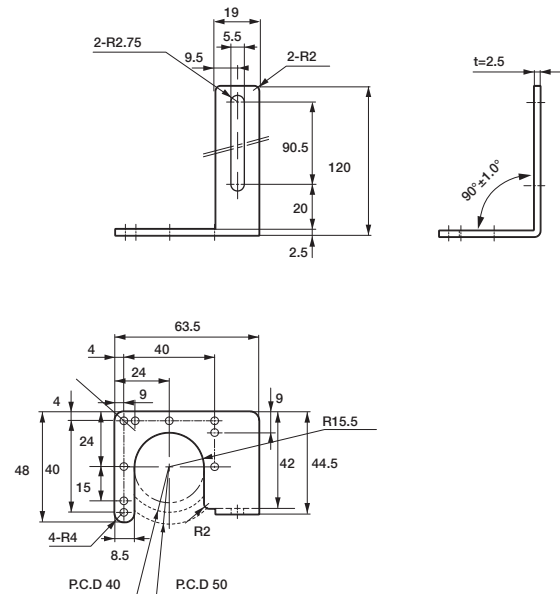

Mounting bracket for OPB-5015W2-B/OPB-10015W2-B/OPB-15015W2-B

Model No. : BKT-MVS-OPDB-01

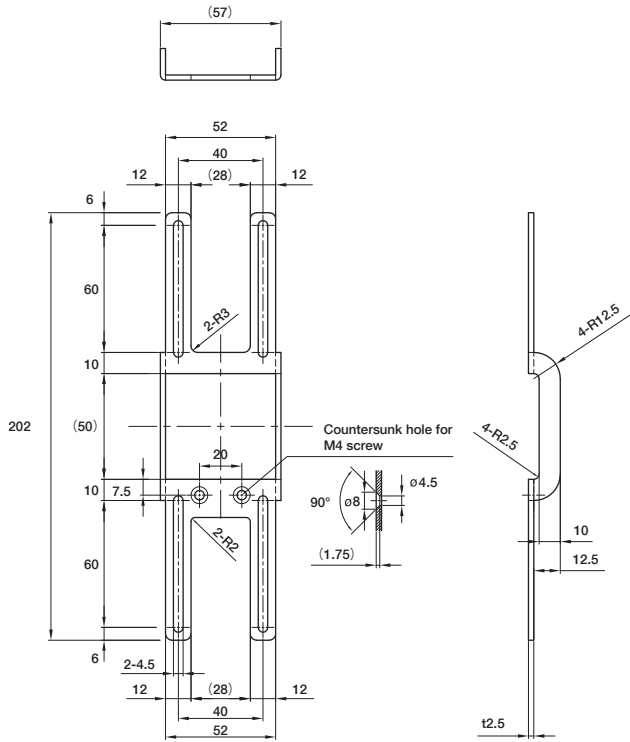

Model No. : BKT-MVS-OPDB-01-20

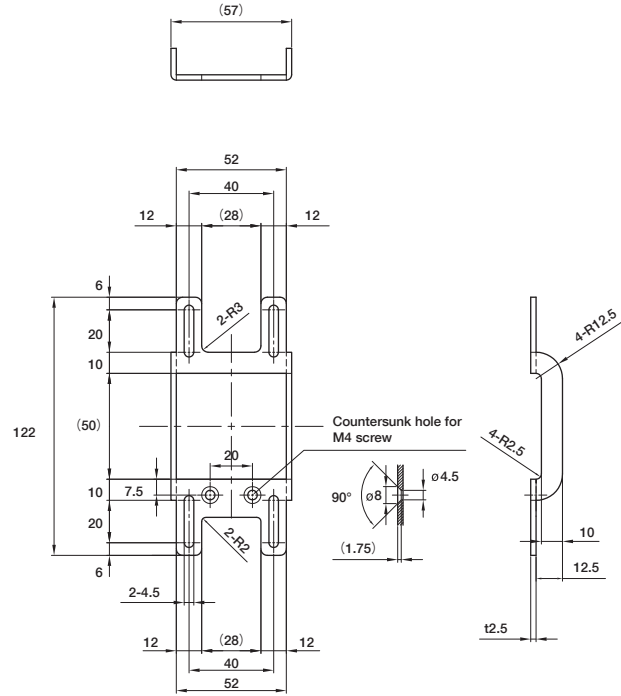

Model No. : BKT-MVS-OPDB-02

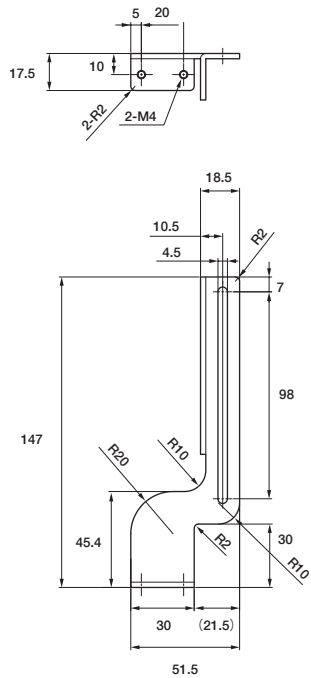

BKT-MVS-OPDB-01 and BKT-MVS-OPDB-02 (Example)

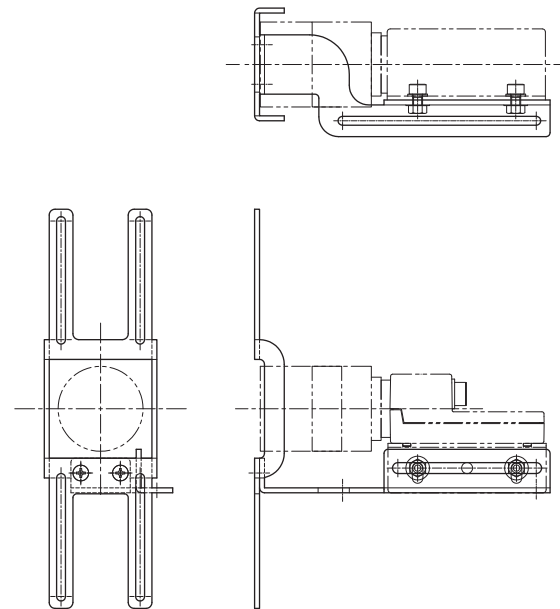

# SPECIFICATIONS

MVS Series

CVS Series

MVS Series APPLICATION

MVS-PM-R/EM-R

MVS-OCR2

OPTIONS

Model	MVS-PM-R MVS-EM-R Common Specifications
Supply Voltage	DC 6VDC ±10% (From Controller)
Power consumption	Max. 100mA / 24V DC (in Controller)
Image sensor	430000 Pixel 1/3" CCD Color Image Sensor
Resolution	512 X 512 (512 X 256 by interlace processing)
Pixel size	H: 6.5 X V: 6.3µm (512 X 512 => 3.33 X 3.23 mm)
Lens type	CS mount (C mount adapter is included)
Communication I/F	LVDS (100Mbps) dedicated to Controller (Max. 10m)
Indicator	LED (Power, Status)
Operating Temp., Humid.	0-50°C, 35-85%/RH (Non Condensing)
Storage Temp., Humid.	-20-70°C, 25-95%/RH (Non Condensing)
Vibration, Shock	Vibration : 10~ 55Hz /1.5mm, Shock : 15G
Regulatory compliance	CE (EMC: 2004/108/EC) / RoHS: 2011/65/EU EMC standards (EN 61000-6-2, EN 61000-6-4)
Material	Aluminum
Protection Category	IP50 (IEC 60529)
Weight	Approx. 90g
Accessories	C mount adapter, mounting bracket

Model	MVS-PM-R Specifications
Image processing function	<ul style="list-style-type: none"> <li>- Rotation Search up to +/- 180 degree</li> <li>- 16 Inspection Window</li> <li>- Judgment of Contour and Background, Color Normalized Correlation, Differential Normalized Correlation, Color Shape, Color Area, Stain</li> <li>- Variable shutter speed with continuous capture (up to 6 times)</li> <li>- Automatic Color/Black&amp;White changeover</li> <li>- External Teaching (Auto-Shutter/Threshold/Color Extracting)</li> </ul>

Model	MVS-EM-R Specifications
Measurement function	<ul style="list-style-type: none"> <li>- Rotation Search up to +/- 45 degree</li> <li>- 16 Inspection Window</li> <li>- Measuring Outer/Inner size, Counting number of Edges, Measuring position of Edge, Measuring Edge to Edge, Measuring pitch of Edges</li> <li>- Variable shutter speed with continuous capture (up to 5 times)</li> <li>- Black&amp;White capturing</li> <li>- External Teaching (Auto-Shutter/Threshold/Auto function selection)</li> </ul>

Model	MVS-OCR2 Specifications
Supply Voltage	DC 6VDC ±10% (From Controller)
Power consumption	Max. 200mA / 24V DC (in Controller)
Image sensor	1000,000 Pixel 1/1.8" CMOS Color Image Sensor
Resolution	1024 X 1024 progressive
Pixel size	5.42 X 5.42 mm (1024 X 1024)
Lens type	C Mount
Communication I/F	LVDS (100Mbps) dedicated to Controller (Max. 10m)
Indicator	LED (Power, Status)
Response time	Approx. 48ms (2 lines, 20 characters, No search) Varies by shutter speed, inspection window size, etc.
Operating Temp., Humid.	0-50°C, 35-85%/RH (Non Condensing)
Storage Temp., Humid.	-20-70°C, 25-95%/RH (Non Condensing)
Vibration resistance	Vibration : 10~ 55Hz /1.5mm, X,Y,Z for 2 hours
Shock resistance	Approx. 15G, X,Y,Z 3 times each
Regulatory compliance	CE (EMC: 2004/108/EC) / RoHS: 2011/65/EU EMC standards (EN 61000-6-2, EN 61000-6-4)
Material	Aluminum
Protection Category	IP50 (IEC 60529)
Weight	Approx. 140g
Accessories	Mounting bracket
Image processing function	<ul style="list-style-type: none"> <li>- Rotation Search up to +/- 180 degree</li> <li>- 4 Inspection Window</li> <li>- Up to 6 lines and up to 60 characters per one inspection window. Up to 120 characters are recognizable totally.</li> <li>- Up to 2 DATE and 2 TIME and 4 strings (total 4)</li> <li>- User-defined dictionary : 1500 characters managed in 3 groups of 500 each</li> <li>- Available Date/Time code recognition: Month: 1 character, Date: 2 char., Hour: 1 char., Minutes: 1 char.</li> <li>- Variable shutter speed with continuous capturing (up to 6 times)</li> <li>- Automatic Color/Black&amp;White changeover</li> <li>- External Teaching (Auto-Shutter/Threshold/Color Extracting)</li> </ul>

# SPECIFICATIONS

<b>Model</b>	<b>MVS-DN/DP/DN-E/DP-E</b>
<b>Supply Voltage</b>	DC 24V ±10% (DC 12V is possible without external Light)
<b>Power consumption</b>	Controller : Max. 80mA / 24V DC, With external light : max 1.5A (150% of Light power consumption)+ Power consumption of all camera heads
<b>Number of camera</b>	Max. 3 heads
<b>Output</b>	NPN/PNP open collector Residual voltage is less 1.0V, OK, NG : 1 each for every camera head (Total: 6) max. 100mA, Auxiliary output : Total 20, max. 50mA
<b>Input</b>	Synchronous: 3, Auxiliary: 10
<b>I/O connector</b>	Power/OK/NG/Synchronous : Terminal block 12P, Expansive I/O : IEEE1284 half pitch connector 50P
<b>External Light out</b>	12V PWM control (87kHz, 256steps) Out: 3, Total 24W
<b>Communication I/F</b>	USB1.1 (max 12Mbps) : USB standard connector, RS232 (max 500kbps) : D-Sub 9P, RJ45 (8P8C) : Ethernet (10BaseT/100BaseTX) MVS-DN-E / DP-E only
<b>Display, Control device</b>	4.3" wide TFT LCD, Touchscreen, Panel SW, Indicator : Power, Camera No.LED
<b>Timer accuracy</b>	-45sec. ~ +1min. 15sec. Per Month (Typical)
<b>Timer backup battery</b>	primary cell : 5 year with power off (Typical), secondary super capacitor : 7.8 year (Typical with 3 days backup)
<b>Operating Temp., Humid.</b>	0~50°C, 35~85%/RH (Non Condensing)
<b>Storage Temp., Humid</b>	-20~70°C, 25~95%/RH (Non Condensing)
<b>Vibration, Shock</b>	Vibration : 10~ 55Hz /1.5mm, Shock : 10G
<b>Regulatory compliance</b>	CE (EMC: 2004/108/EC) / RoHS: 2011/65/EU EMC standards (EN 61000-6-2, EN 61000-6-4)
<b>Material</b>	polycarbonate
<b>Protection</b>	IP20 (IEC 60529)
<b>Weight</b>	Approx. 570g
<b>Attachment</b>	Panel mount bracket