

Low cost/Small type

**Z3** series**New industry standard sensor**

| Longest sensing distance in class at 25 m\*

| Significantly reduced dead zone

| Indicators visible from any angle

\*Red LED type, with through-beam type

**FASTUS**  
 FASTUS is a product brand of Optex FA.
**Related products**

Laser type

**Z-L**  
 ● P.272

Sensor head for amplifier separate type

**Z3R-Q**  
 ● P.404

BGS type

**BGS-Z**  
 ● P.326
**Selection table**

Type	Shape	Sensing distance	Model (Models in parentheses are connector types)	
			NPN type	PNP type
Through-beam		25 m	<b>Z3T-2500N</b> (Z3T-2500CN4)	<b>Z3T-2500P</b> (Z3T-2500CP4)
Retro-reflective		0.01 to 4 m	<b>Z3R-400N</b> (Z3R-400CN4)	<b>Z3R-400P</b> (Z3R-400CP4)
Diffuse-reflective		0 to 1 m	<b>Z3D-100N</b> (Z3D-100CN4)	<b>Z3D-100P</b> (Z3D-100CP4)
Limited diffuse reflective		10 to 90 mm	<b>Z3D-L09N</b> (Z3D-L09CN4)	<b>Z3D-L09P</b> (Z3D-L09CP4)
Wide angle diffuse reflective		1 to 200 mm	<b>Z3D-W20N</b> (Z3D-W20CN4)	<b>Z3D-W20P</b> (Z3D-W20CP4)
Transparent object detection		0.01 to 2 m	<b>Z3R-Q200N</b> (Z3R-Q200CN4) ● P.404	<b>Z3R-Q200P</b> (Z3R-Q200CP4) ● P.404

- A mounting bracket is not included. If necessary, please purchase separately.
- A reflector is not included with the retro-reflective type. Please purchase an optional reflector separately.
- For the connector type, please purchase an optional connector cable separately.
- For the sensor head for amplifier separate type, please refer to P.404.

**Options/Accessories****Reflector**

Standard

**V-61**  
 60.9 × 50.9 mm  
 Sensing distance:  
 Z3R-400□  
 0.01 to 4 m

Small type

**V-42**  
 42 × 35 mm  
 Sensing distance:  
 Z3R-400□  
 0.01 to 2.4 m

Vertical type

**P45A**  
 54 × 12.4 mm  
 Sensing distance:  
 Z3R-400□  
 0.01 to 1.4 m

Side mount

**P25**  
 32 × 14 mm  
 Sensing distance:  
 Z3R-400□  
 0.01 to 1.6 m

Ultra-small

**V-30**  
 43 × 23 mm  
 Sensing distance:  
 Z3R-400□  
 0.01 to 2.2 m
**Reflective sheet**
**Diamond grade sheet**  
 Sensing distance:  
 Z3R-400□  
 0.1 to 1 m  
 100 × 100 mm  
 (adhesive type)
**Connector cables**

Straight

**JCN-S**  
 Cable length: 2 m  
**JCN-5S**  
 Cable length: 5 m  
**JCN-10S**  
 Cable length: 10 m

L-shaped

**JCN-L**  
 Cable length: 2 m  
**JCN-5L**  
 Cable length: 5 m  
**JCN-10L**  
 Cable length: 10 m

# World-renowned Z series basic photoelectric sensors continue to evolve.

Total volume of Z series photoelectric sensors sold around the world exceeds 3 million units. The FASTUS Z3 series built-in amplifier photoelectric sensors with improved detection performance is the successor of the easy-to-use Z series. This series takes the functionality, practicality and cost performance required of general purpose photoelectric sensors to the next level.

Sensing distance **25 m**  
Longest in class

\*Red LED type, with through-beam type

- Features an industry standard mounting pitch of 25.4 mm
- Indicators visible from any angle

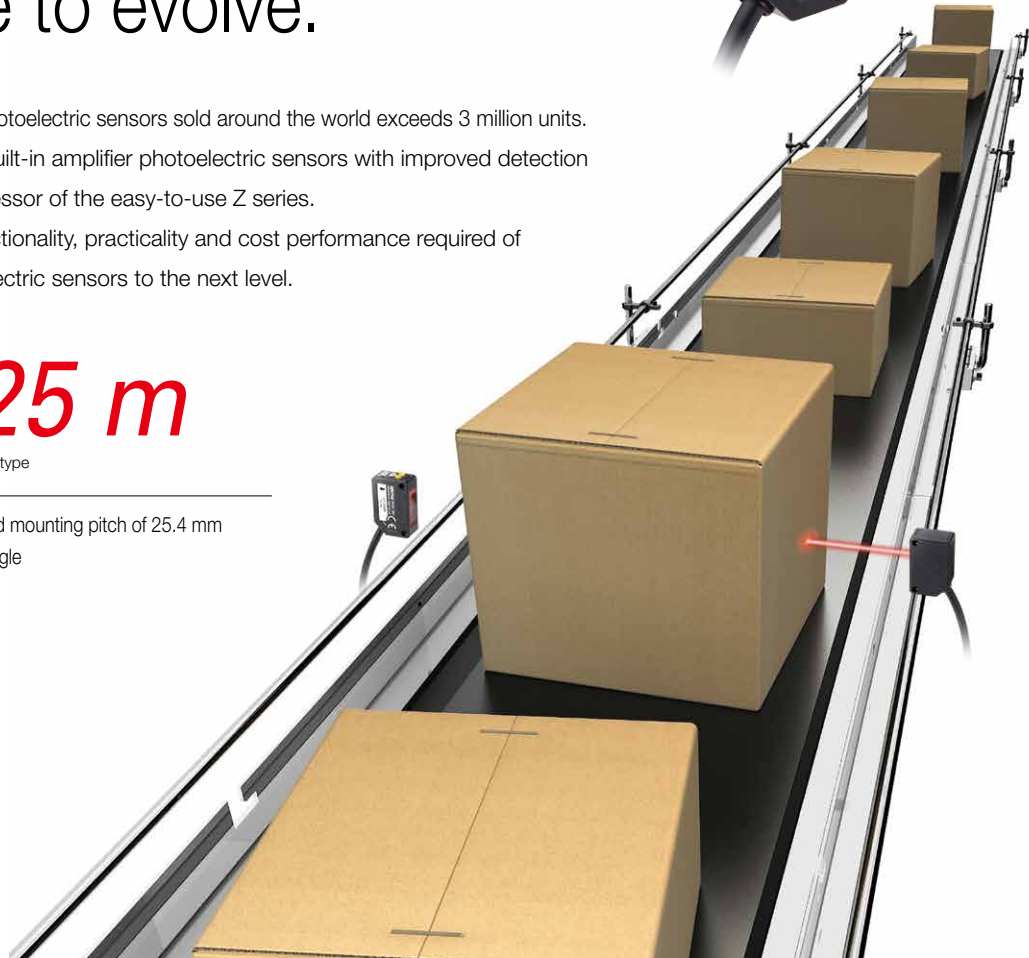

Photoelectric Sensors

Specialized Photoelectric Sensors

Laser Displacement Sensors

Sensors with Built-in Amplifier

Z3

Z-M

Z2

E

J

K

S

S2

C-R

C2

PLN

## Mounting bracket



For cable type  
Floor-mounted  
**BEF-W100-B**



For connector type  
Back-mounted  
**BEF-W100-A**  
Cannot be used with connector cable JCN-□□L.

## Protective mounting bracket

LK series



**LK-501**

- Ultra-durable 2 mm thick type
- Rust-resistant stainless steel
- Sensor is firmly secured using M3 Hex socket head cap screws
- The bracket is also firmly secured using M6 screws



**LK-502**

## Slit mask



Slit mask for through-beam type (adhesive type)

**BL-W100**  
Shipped with two of each slit width (0.5 mm, 1 mm, 2 mm).

## Stainless steel slit mask



Stainless steel slit mask for through-beam type

**BL-100-M1-10pcs**  
**BL-100-M05**  
10 pieces of slit masks are shipped for M1 with a slit width of 1 mm, and 1 piece of slit mask is shipped for M05 with a slit width of 0.5 mm.

## Anti-interference filter



For through-beam type (4 pieces)

**BL-100-POLF**

**Features**

**High power LED provides stable detection**

The Z3 series through-beam type sensor has a 25 m sensing distance, the longest in its class.

The margin for the receiving light quantity has been increased significantly, helping the sensor overcome interference from dust or other fine particles.

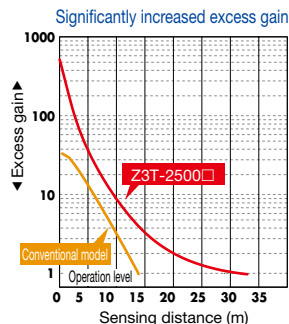
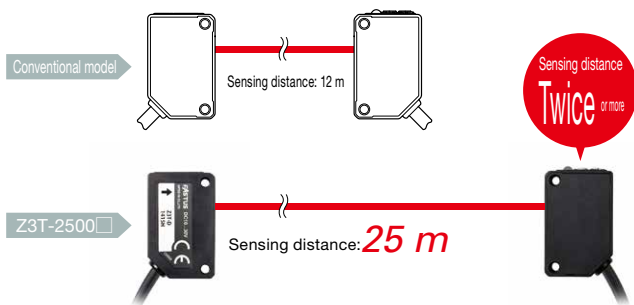

**Plus**

- Easy optical axis adjustment thanks to a large spot size with good visibility
- 4 element LED helps reduce emitting power degradation during long-term use



Through-beam type emitter

**Significantly reduced dead zone**

The diffuse-reflective type features an optimized optical receiver structure that successfully minimizes the dead zone in front of the lens. This makes it easier to detect workpieces with a low reflectivity that pass close to the sensor, even on lines that convey workpieces of varying heights.

**Close-range dead zone (typical value)**

Gray paper (18%)	Conventional model	to 2 mm	
	Z3D-100	0 mm	No dead zone
Black paper (6%)	Conventional model	to 13 mm	
	Z3D-100	to 2 mm	$\frac{1}{6}$ or less compared to conventional model

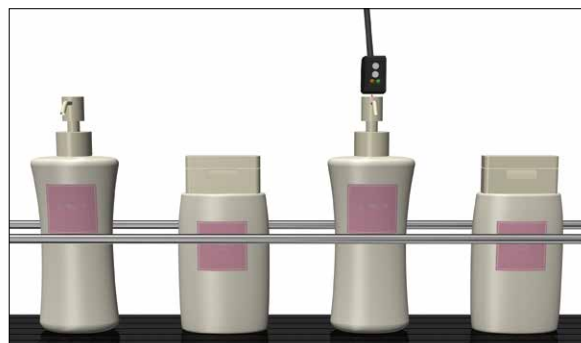

Photoelectric Sensors

Specialized Photoelectric Sensors

Laser Displacement Sensors

Sensors with Built-in Amplifier

Z3

Z-M

Z2

E

J

K

S

S2

C-R

C2

PLN

Type			Through-beam type	Retro-reflective type	Diffuse-reflective type	Limited diffuse reflective type	Wide angle diffuse reflective type
Model	NPN	Cable type	<b>Z3T-2500N</b>	<b>Z3R-400N</b>	<b>Z3D-100N</b>	<b>Z3D-L09N</b>	<b>Z3D-W20N</b>
		Connector type	<b>Z3T-2500CN4</b>	<b>Z3R-400CN4</b>	<b>Z3D-100CN4</b>	<b>Z3D-L09CN4</b>	<b>Z3D-W20CN4</b>
	PNP	Cable type	<b>Z3T-2500P</b>	<b>Z3R-400P</b>	<b>Z3D-100P</b>	<b>Z3D-L09P</b>	<b>Z3D-W20P</b>
		Connector type	<b>Z3T-2500CP4</b>	<b>Z3R-400CP4</b>	<b>Z3D-100CP4</b>	<b>Z3D-L09CP4</b>	<b>Z3D-W20CP4</b>
Sensing distance			25 m	0.01 to 4 m <sup>*1</sup>	0 to 1 m <sup>*2</sup>	10 to 90 mm <sup>*3</sup>	1 to 200 mm <sup>*4</sup>
Light source			4 element red LED, wavelength 632 nm				
Spot size			Approx. ø1800 mm (at distance of 25 m)	Approx. ø280 mm (at distance of 4 m)	Approx. ø75 mm (at distance of 1 m)	Approx. ø8 mm (at distance of 90 mm)	Approx. □45 mm (at distance of 50 mm)
Response time			500 µs or less				
Hysteresis			—	—	20% Max.	10% Max.	20% Max.
Distance adjustment			1-turn potentiometer				
Indicators			Output indicator: orange LED, Stability indicator: green LED (no indicator equipped on through-beam type emitter)				
Control output			NPN/PNP type Open collector Max. 100 mA/30 VDC				
Output mode			Light ON / Dark ON selection switch				
Connection type			Cable type: Cable length: 2 m ø3.8 mm / Connector type: M8, 4-pin				
Rating	Supply voltage		10 to 30 VDC, including 10% ripple (p-p)				
	Current consumption		Emitter: 20 mA or less Receiver: 15 mA or less	20 mA or less	25 mA or less	20 mA or less	20 mA or less
Applicable regulations			EMC directive (2004/108/EC)				
Applicable standards			EN 60947-5-2				
Company standards			Noise resistance: Feilen Level 3 cleared				
Environmental resistance	Ambient temperature/humidity		-25 to +55°C (no freezing) / 35 to 85% RH (no condensation)				
	Ambient illuminance		Sunlight: 10,000 lx Incandescent lamp: 3,000 lx				
	Vibration resistance		10 to 55 Hz; double amplitude 1.5 mm; 2 hours in each of the X, Y, and Z directions				
	Shock resistance		Approx. 100 G (1000 m/s <sup>2</sup> ); 3 times in each of the X, Y, and Z directions				
	Degree of protection		IP67				
Material			Housing: ABS, Front cover: PMMA				
Weight without cable			Approx. 10 g				
Included accessories			Instruction manual				

\*1. With the V-61 reflector

\*2. Using a 200 × 200 mm white sheet of paper.

\*3. Using a 100 × 100 mm white sheet of paper.

\*4. Using a 300 × 300 mm white sheet of paper.

● Specifications are subject to change without prior notice for product improvement purposes.

## Output circuit diagram

### NPN output type

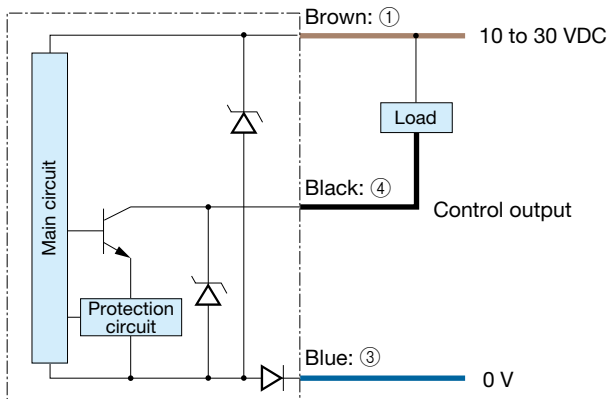

### PNP output type

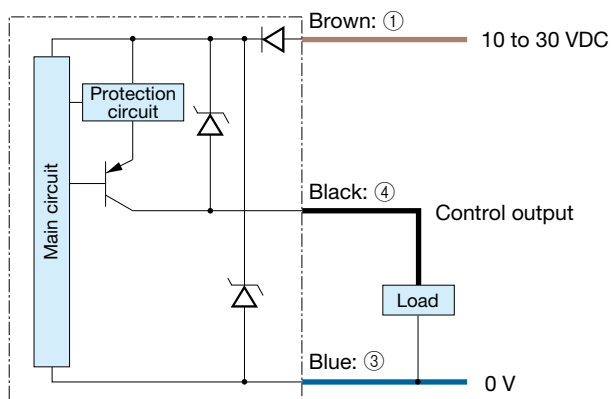

### Through-beam type emitter

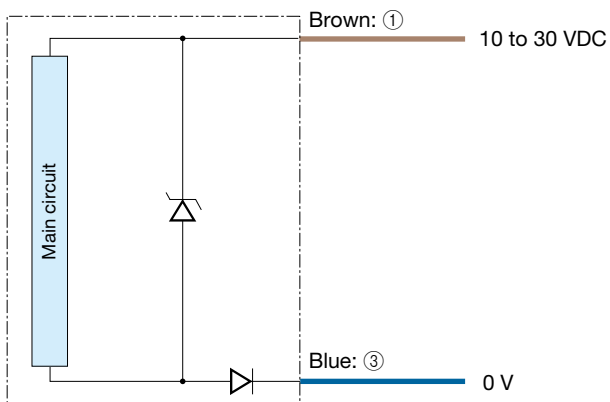

### Connector type

(Pin configuration) Sensor side Connector cable side



- ① 10 to 30 VDC
- ② —
- ③ 0 V
- ④ Control output

### Connecting

■ ① to ④ are connector pin No.

### Notes

- When using a switching regulator for the power supply, be sure to ground the frame ground terminal.
- Because wiring sensor wires with high-voltage wires or power supply wires can result in malfunctions due to noise, which can cause damage, make sure to wire separately.
- Avoid using the transient state while the power is on (approx. 100 ms).
- The connector direction is fixed as the drawing below when you use L-shaped connector cable. Be aware that rotation is not possible.

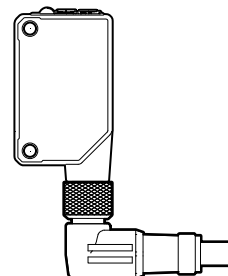

## Dimensions

### Sensor

(Unit: mm)

#### ■ Cable type

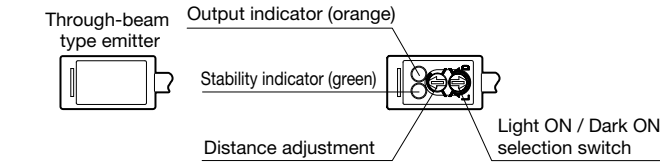

#### ■ Connector type

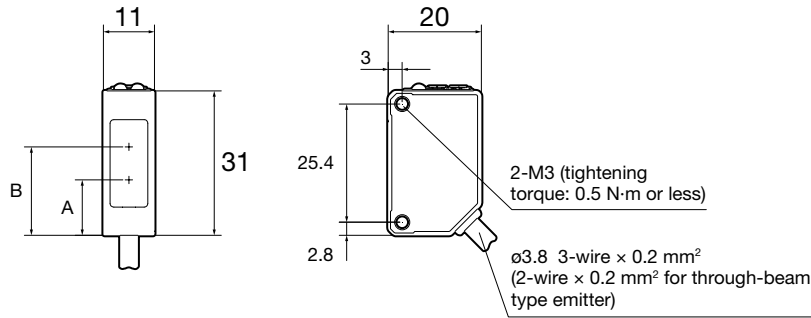

Detection type	A: optical axis of emitter	B: optical axis of receiver
Through-beam type	-	19 (optical axis of emitter/receiver)
Diffuse-reflective type	11.9	19
Retro-reflective type		19
Wide angle diffuse reflective type		18.8
Limited diffuse reflective type		

### Mounting bracket

#### ■ BEF-W100-B

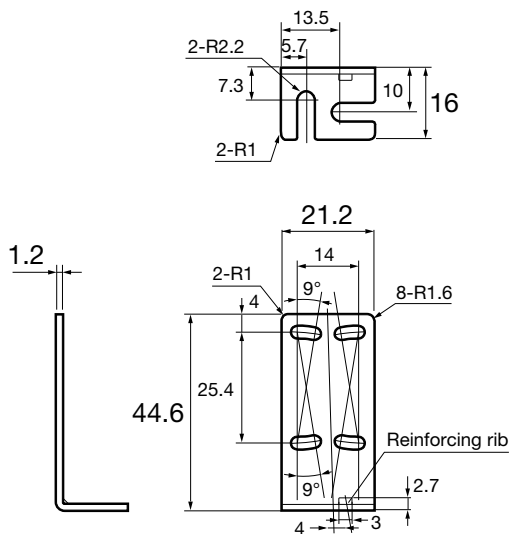

#### ■ BEF-W100-A

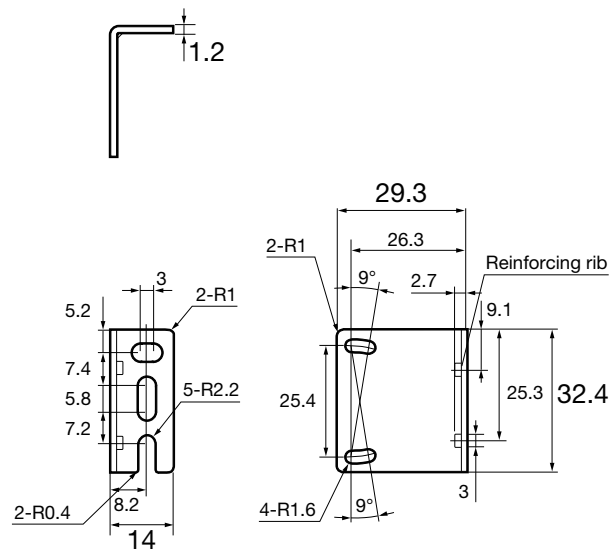

Photoelectric Sensors

Specialized Photoelectric Sensors

Laser Displacement Sensors

Sensors with Built-in Amplifier

Z3

Z-M

Z2

E

J

K

S

S2

C-R

C2

PLN

Dimensions

Reflector

(Unit: mm)

■ V-61: Standard type reflector

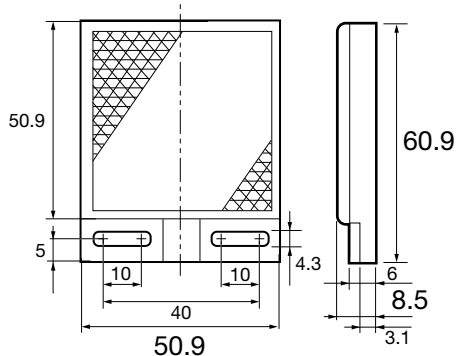

■ V-42: Small reflector

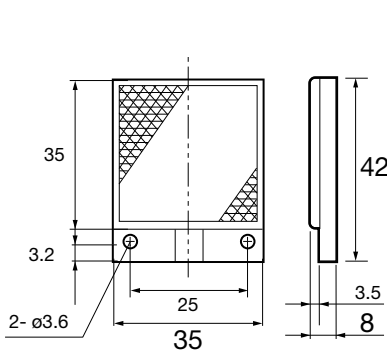

■ P45A: Vertical type reflector

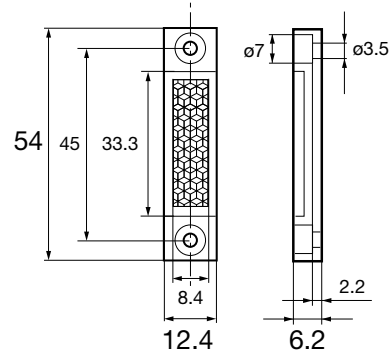

■ P25: Side mount reflector

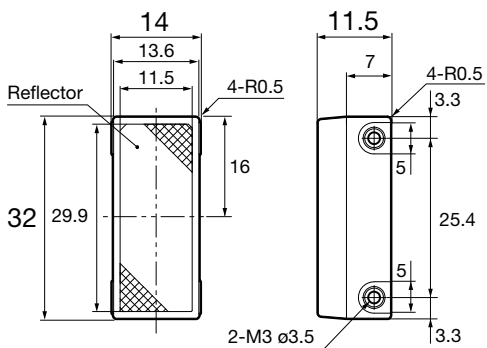

■ V-30: Ultra-small reflector

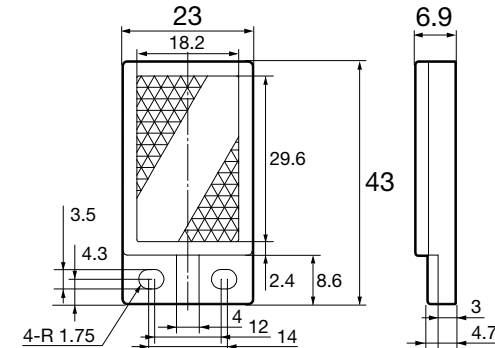

Protective mounting bracket

■ LK-S01

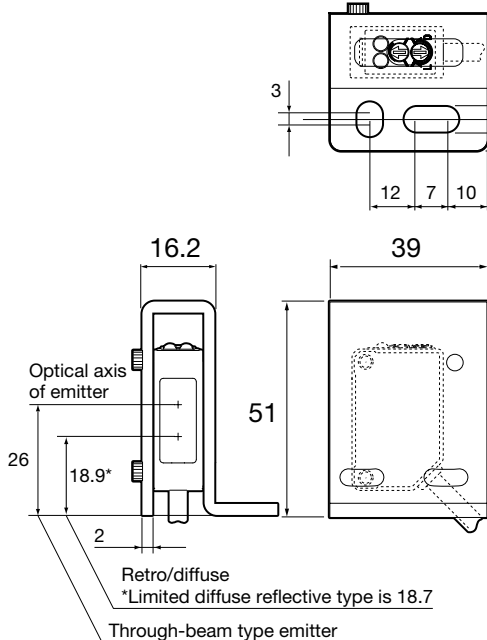

■ LK-S02

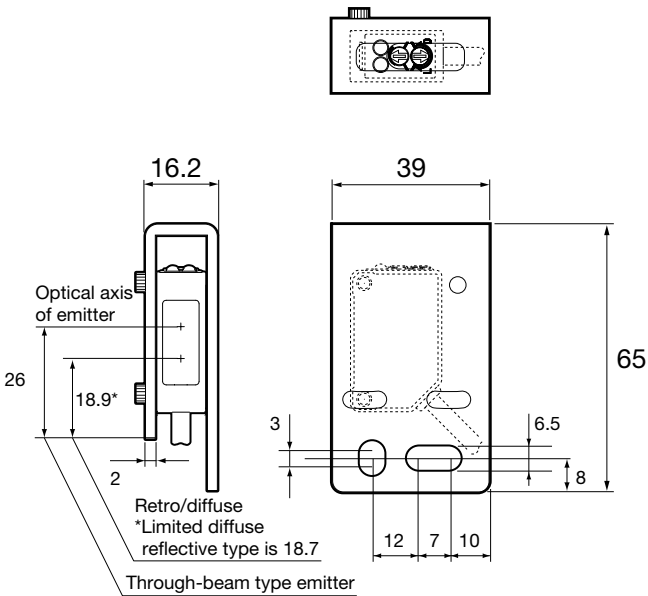

Photoelectric Sensors

Specialized Photoelectric Sensors

Laser Displacement Sensors

Sensors with Built-in Amplifier

Z3

Z-M

Z2

E

J

K

S

S2

C-R

C2

PLN

**Connector cable**

(Unit: mm)

■ JCN-S, JCN-5S, JCN-10S

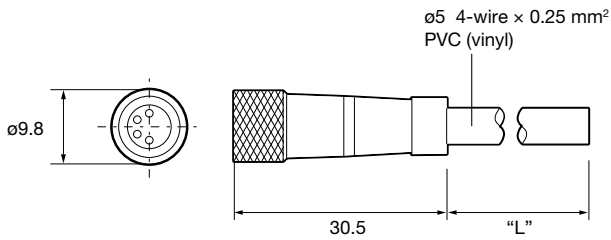

■ JCN-L, JCN-5L, JCN-10L

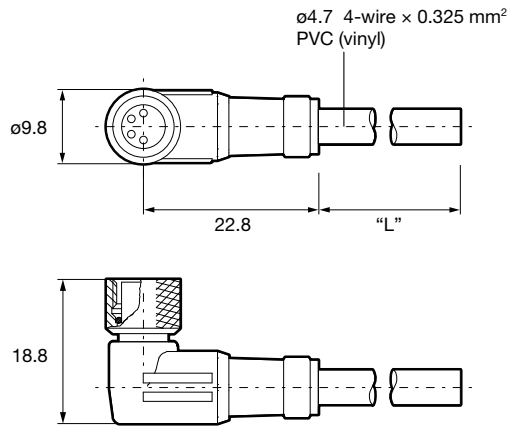

**Slit mask**

■ BL-W100

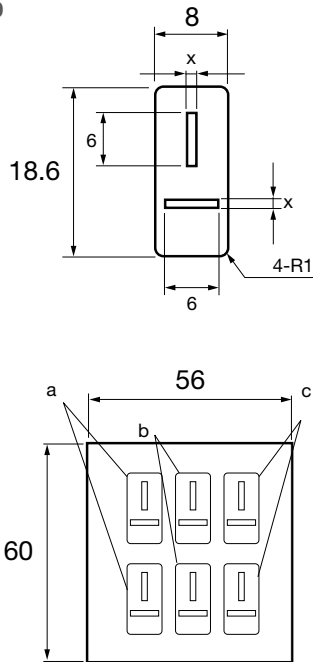

	a	b	c
Slit width X	0.5	1	2
Sensing distance	2 m	4 m	10 m

■ BL-100-M1  
BL-100-M05

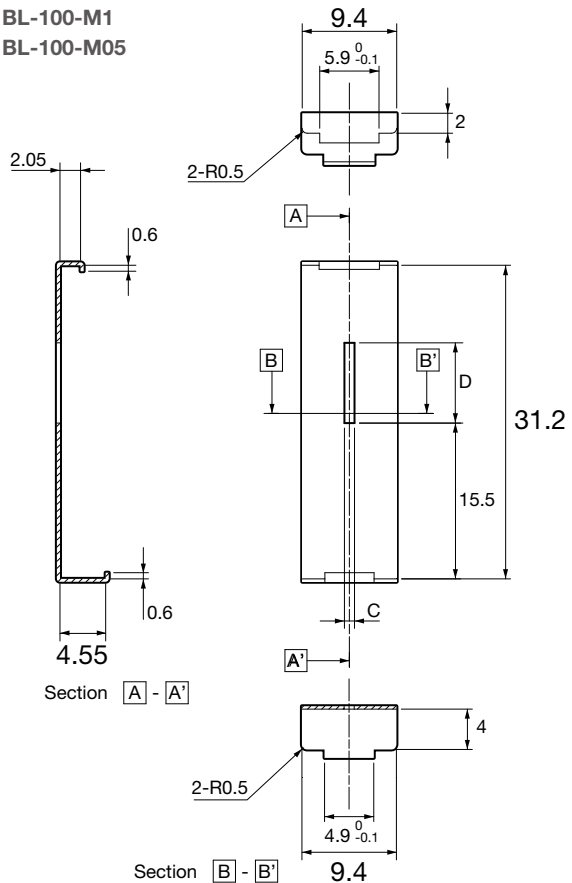

	Slit width C	Slit length D	Sensing distance
BL-100-M1	1.0	8	4 m
BL-100-M05	0.5	6	2 m



Typical characteristic data

Z3T-2500

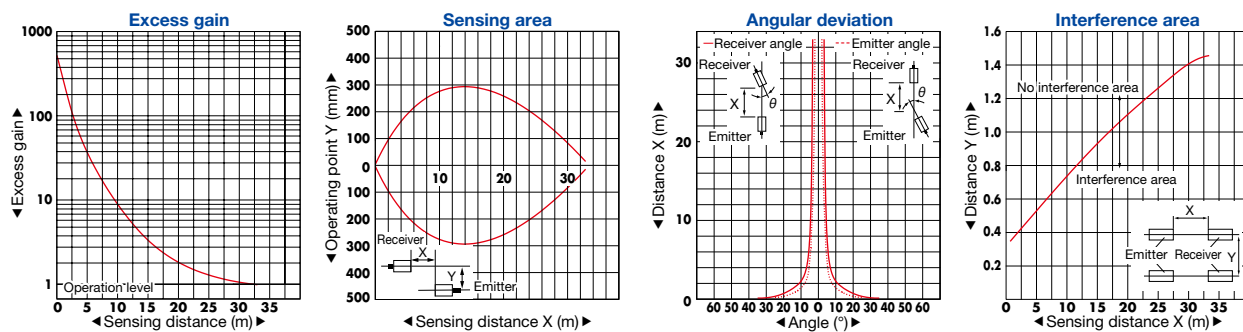

When slit mask is attached Z3T-2500

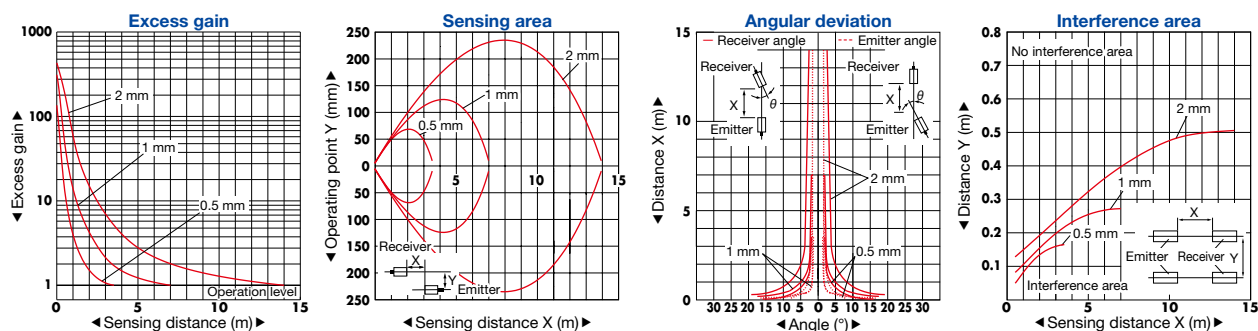

Z3R-400

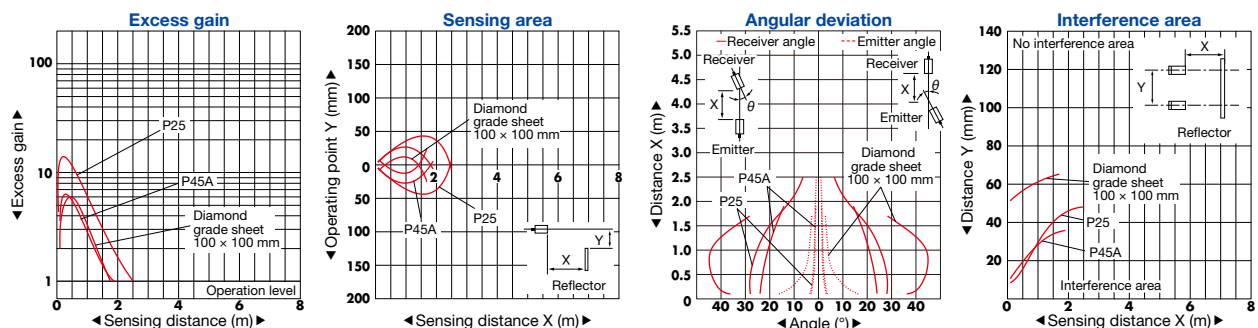
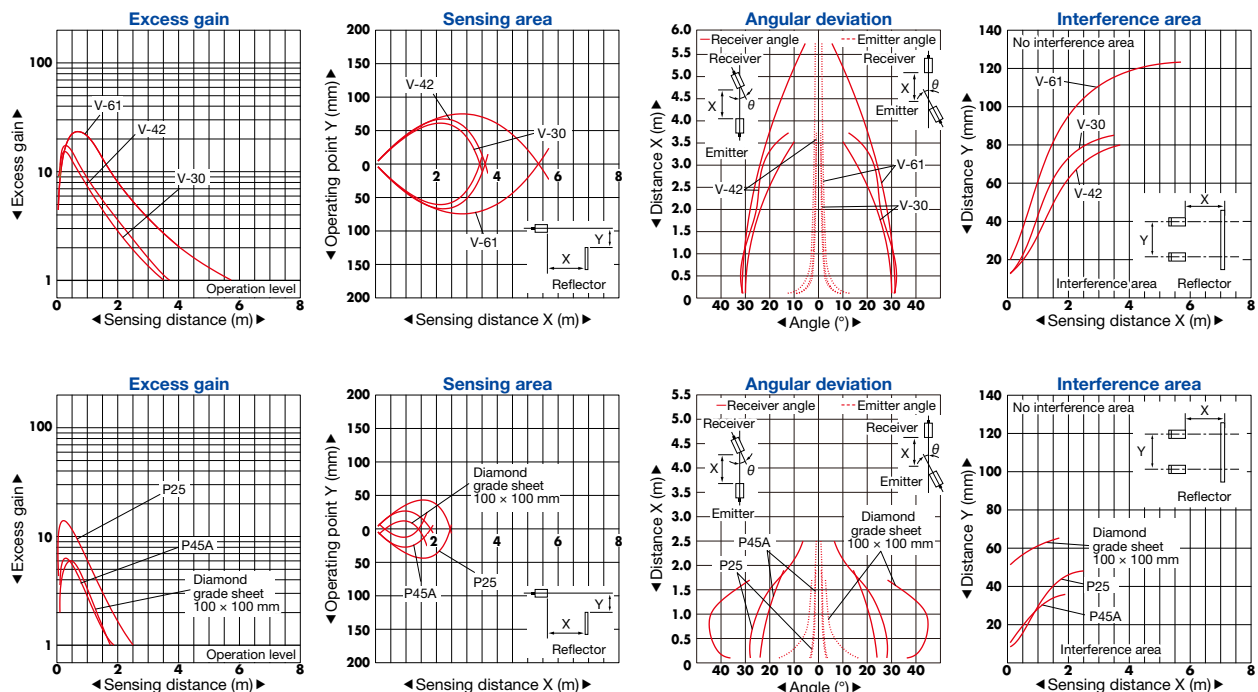

Z3D-100□

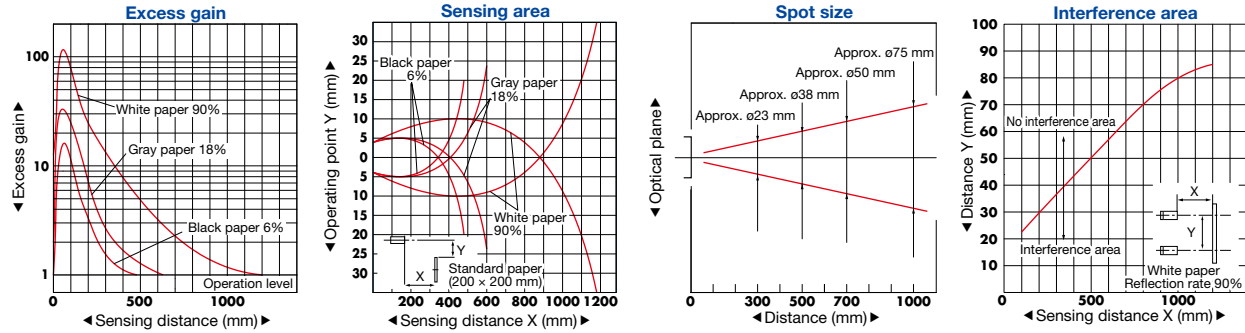

Z3D-L09□

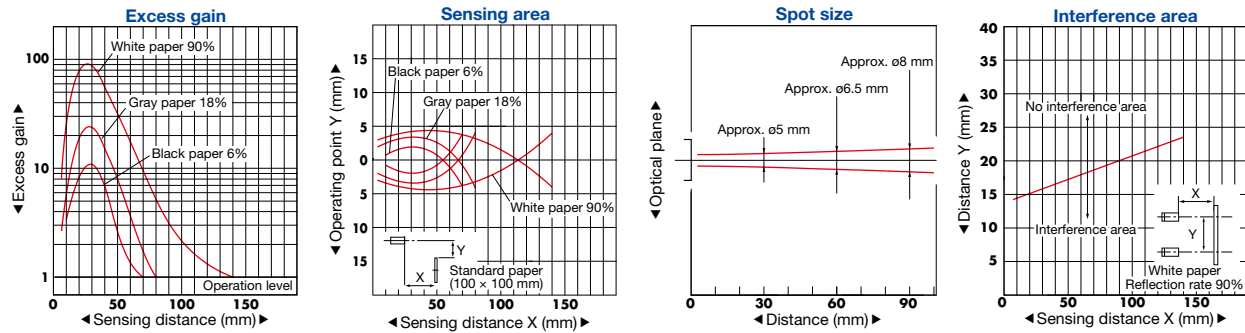

Z3D-W20□

